TAMC863

4 Channel High Speed Sync/Async Serial Interface

Version 1.0

User Manual

Issue 1.0.4

August 2014

TEWS TECHNOLOGIES GmbH

Am Bahnhof 7 25469 Halstenbek, Germany

Phone: +49 (0) 4101 4058 0 Fax: +49 (0) 4101 4058 19

e-mail: info@tews.com www.tews.com

TAMC863-10R

4 Channel High Speed Sync/Async Serial Interface, VHDCI 68p front panel connector, Mid-Size front panel

TAMC863-11R

4 Channel High Speed Sync/Async Serial Interface, VHDCI 68p front panel connector, Full-Size front panel

This document contains information, which is proprietary to TEWS TECHNOLOGIES GmbH. Any reproduction without written permission is forbidden.

TEWS TECHNOLOGIES GmbH has made any effort to ensure that this manual is accurate and complete. However TEWS TECHNOLOGIES GmbH reserves the right to change the product described in this document at any time without notice.

TEWS TECHNOLOGIES GmbH is not liable for any damage arising out of the application or use of the device described herein.

Style Conventions

Hexadecimal characters are specified with prefix 0x, i.e. 0x029E (that means hexadecimal value 029E).

For signals on hardware products, an 'Active Low' is represented by the signal name with # following, i.e. IP_RESET#.

Access terms are described as:

W	Write Only
R	Read Only
R/W	Read/Write
R/C	Read/Clear
R/S	Read/Set

©2014 by TEWS TECHNOLOGIES GmbH

All trademarks mentioned are property of their respective owners.

Issue	Description	Date
1.0.0	Initial Issue	July 2010
1.0.1	Added power requirement values to the technical specification table	January 2011
1.0.2	Added -11 board option	December 2011
1.0.3	- PCI Subsystem-ID is the same for both board options -10R (mid size front panel) and -11R (full size front panel). - added note regarding receive data buffer size	September 2012
1.0.4	General Revision	August 2014

Table of Contents

1	PRODUCT DESCRIPTION	8
2	TECHNICAL SPECIFICATION	9
3	HANDLING AND OPERATION INSTRUCTIONS	11
	3.1 ESD Protection	11
4	ON BOARD DEVICES	12
	4.1 Overview	12
	4.2 PEX8112 PCIe/PCI Bridge	12
	4.2.1 PEX8112 Register Map.....	12
	4.2.2 PCI Express Configuration Space Register Mapping	13
	4.2.3 Configuration EEPROM	14
	4.3 SCC FPGA.....	15
	4.3.1 PCI Configuration Space.....	15
5	ADDRESS MAP	16
	5.1 Register Space	16
	5.2 Register Map.....	16
	5.3 Global Register Map	17
	5.4 SCC Register Map.....	18
	5.5 Global Registers.....	20
	5.5.1 GCMR – Global Command Register (0x0000).....	20
	5.5.2 GSTAR – Global Status Register (0x0004)	23
	5.5.3 GMODE – Global Mode Register (0x0008)	24
	5.5.4 IQLENR0 – Interrupt Queue Length Register 0 (0x000C)	25
	5.5.5 IQLENR1 – Interrupt Queue Length Register 1 (0x0010).....	25
	5.5.6 IQSCCiRXBAR – Interrupt Queue SCCi Receiver Base Address Register (i=0...3)	26
	5.5.7 IQSCCiTXBAR – Interrupt Queue SCCi Transmitter Base Address Register (i=0...3)	26
	5.5.8 FIFOCR4 – FIFO Control Register 4 (0x0034)	27
	5.5.9 IQCFGBAR – Interrupt Queue Configuration Base Address Register (0x003C).....	28
	5.5.10 FIFOCR1 – FIFO Control Register 1 (0x0044).....	28
	5.5.11 CHiCFG – Channel i Configuration Register (i=0...3)	29
	5.5.12 CHiBRDA – Channel i Base Receive Descriptor Address Register (i=0...3).....	31
	5.5.13 CHiBTDA – Channel i Base Transmit Descriptor Address Register (i=0...3)	31
	5.5.14 CHiFRDA – Channel i First (Current) Receive Descriptor Address Register (i=0...3) ..	31
	5.5.15 CHiFTDA – Channel i First (Current) Transmit Descriptor Address Register (i=0...3) ..	31
	5.5.16 CHiLRDA – Channel i Last Receive Descriptor Address Register (i=0...3)	31
	5.5.17 CHiLTDA – Channel i Last Transmit Descriptor Address Register (i=0...3)	32
	5.5.18 VR – Version Register (0x00F0).....	32
	5.5.19 ISPR – In-System-Programming Register (0x00F4)	32
	5.5.20 GCTLR – Global Control Register (0x00F8).....	33
	5.6 SCC Channel Specific Registers	34
	5.6.1 CMDR – Command Register (0x0100, 0x0180, 0x0200, 0x0280)	34
	5.6.2 STAR – Status Register (0x0104, 0x0184, 0x0204, 0x0284)	35
	5.6.3 CCR0 – Channel Configuration Register 0 (0x0108, 0x0188, 0x0208, 0x0288)	36
	5.6.4 CCR1 – Configuration Register 1 (0x010C, 0x018C, 0x020C, 0x028C)	37
	5.6.5 CCR2 – Channel Configuration Register 2 (0x0110, 0x0190, 0x0210, 0x0290)	40
	5.6.6 BRR – Baud Rate Register (0x012C, 0x01AC, 0x022C, 0x02AC).....	43
	5.6.7 TCR – Termination Character Register (0x0148, 0x01C8, 0x0248, 0x02C8)	43
	5.6.8 IMR – Interrupt Mask Register (0x0154, 0x01D4, 0x0254, 0x02D4).....	44
	5.6.9 ISR – Interrupt Status Register (0x0158, 0x01D8, 0x0258, 0x02D8).....	45
	5.6.10 ACR – Additional Configuration Register (0x015C, 0x01DC, 0x025C, 0x02DC).....	47

6	FUNCTIONAL DESCRIPTION	50
6.1	DMA Controller	50
6.1.1	DMAC Transmit Descriptor Lists.....	51
6.1.2	DMAC Receive Descriptor Lists.....	53
6.2	DMAC Interrupt Controller	56
6.2.1	DMA Controller initiated Interrupts.....	56
6.2.2	Interrupt Vector Description	57
7	SERIAL COMMUNICATION CONTROLLER.....	61
7.1	Protocol Description.....	61
7.1.1	HDLC Mode	61
7.1.2	Asynchronous (ASYNC) Mode	62
7.2	Clock Sources	64
7.3	Baud Rate Generation	64
7.4	Data Encoding	65
7.4.1	NRZ and NRZI Encoding	65
7.4.2	FM0 and FM1 Encoding.....	66
7.4.3	Manchester Encoding	66
7.5	Clock Recovery (DPLL)	67
8	CONFIGURATION HINTS	68
8.1	Big / Little Endian	68
8.2	Configuration EEPROM.....	68
8.3	Additional Termination Resistors	69
8.4	Transmit & Receive Clock Polarity.....	70
9	MODULE MANAGEMENT.....	71
9.1	Indicators	71
9.1.1	Front Panel LEDs (MMC controlled)	71
9.1.2	On Board LEDs.....	71
9.2	Temperature and Voltage Sensors.....	71
9.3	Connectivity.....	72
10	INSTALLATION.....	73
10.1	AMC Module Insertion & Hot-Swap.....	73
10.1.1	Insertion	73
10.1.2	Extraction.....	73
11	PIN ASSIGNMENT – I/O CONNECTOR	74
11.1	Front Panel & I/O Connector.....	74

List of Figures

FIGURE 1-1 : BLOCK DIAGRAM.....	8
FIGURE 6-1 : FPGA ON-CHIP BLOCK DIAGRAM	50
FIGURE 7-1 : HDLC ADDRESS MODE 0.....	61
FIGURE 7-2 : CLOCK SOURCES	64
FIGURE 7-3 : NRZ AND NRZI DATA ENCODING	65
FIGURE 7-4 : FM0 AND FM1 DATA ENCODING.....	66
FIGURE 7-5 : MANCHESTER DATA ENCODING	67
FIGURE 8-1 : TRANSMIT & RECEIVE CLOCK POLARITY.....	70
FIGURE 11-1: FRONT PANEL & I/O CONNECTOR.....	74

List of Tables

TABLE 2-1 : TECHNICAL SPECIFICATION.....	10
TABLE 4-1 : PEX8112 REGISTER MAP	12
TABLE 4-2 : PEX8112 PCI-COMPATIBLE CONFIGURATION (TYPE 1) REGISTERS.....	13
TABLE 4-3 : PEX8112 PCI-COMPATIBLE EXTENDED CAPABILITY REGISTERS.....	14
TABLE 4-4 : PCI CONFIGURATION SPACE	15
TABLE 5-1 : REGISTER SPACE	16
TABLE 5-2 : REGISTER MAP.....	16
TABLE 5-3 : GLOBAL REGISTER MAP	18
TABLE 5-4 : SCC REGISTER MAP	19
TABLE 5-5 : GLOBAL COMMAND REGISTER	22
TABLE 5-6 : GLOBAL STATUS REGISTER.....	24
TABLE 5-7 : GLOBAL MODE REGISTER	24
TABLE 5-8 : INTERRUPT QUEUE LENGTH REGISTER 0	25
TABLE 5-9 : INTERRUPT QUEUE LENGTH REGISTER 1	25
TABLE 5-10: IQSCCIRXBAR REGISTER.....	26
TABLE 5-11: IQSCCITXBAR REGISTER	26
TABLE 5-12 : FIFO CONTROL REGISTER 4.....	27
TABLE 5-13: IQCFGBAR REGISTER.....	28
TABLE 5-14: FIFO CONTROL REGISTER 1.....	28
TABLE 5-15: CHICFG REGISTER.....	30
TABLE 5-16: CHIBRDA REGISTER	31
TABLE 5-17: CHIBTDA REGISTER.....	31
TABLE 5-18: CHIFRDA REGISTER	31
TABLE 5-19: CHIFTDA REGISTER.....	31
TABLE 5-20: CHILRDA REGISTER.....	32
TABLE 5-21: CHILTDA REGISTER	32
TABLE 5-22: VERSION REGISTER	32
TABLE 5-23: GLOBAL CONTROL REGISTER	33

TABLE 5-24: COMMAND REGISTER	34
TABLE 5-25: STATUS REGISTER	35
TABLE 5-26: CHANNEL CONFIGURATION REGISTER 0	37
TABLE 5-27: CHANNEL CONFIGURATION REGISTER 1	39
TABLE 5-28: CHANNEL CONFIGURATION REGISTER 2	41
TABLE 5-29: BAUD RATE REGISTER	43
TABLE 5-30: TERMINATION CHARACTER REGISTER	43
TABLE 5-31: INTERRUPT MASK REGISTER.....	44
TABLE 5-32: INTERRUPT STATUS REGISTER.....	46
TABLE 5-33: ADDITIONAL CONFIGURATION REGISTER	48
TABLE 5-34: PHYSICAL INTERFACE MODE SELECTION	49
TABLE 6-1 : TRANSMIT DESCRIPTOR.....	51
TABLE 6-2 : RECEIVE DESCRIPTOR	53
TABLE 6-3 : RECEIVE DESCRIPTOR STATUS FIELD	55
TABLE 6-4 : RECEIVE DATA SECTION STATUS BYTE (HDLC)	55
TABLE 6-5 : RECEIVE DATA SECTION STATUS BYTE (ASYNC).....	56
TABLE 6-6 : CONFIGURATION INTERRUPT VECTOR.....	57
TABLE 6-7 : DMA INTERRUPT VECTOR	58
TABLE 6-8 : DMA INTERRUPT VECTOR SOURCE-IDS	59
TABLE 6-9 : SCC INTERRUPT VECTOR.....	60
TABLE 6-10: SCC INTERRUPT VECTOR SOURCE-IDS.....	60
TABLE 7-1 : PROTOCOL MODES	61
TABLE 8-1 : CONFIGURATION EEPROM DATA	69
TABLE 9-1 : FRONT PANEL LEDS (MMC CONTROLLED)	71
TABLE 9-2 : ON BOARD LEDS	71
TABLE 9-3 : TEMPERATURE AND VOLTAGE SENSORS	71
TABLE 10-1: AMC MODULE INSERTION.....	73
TABLE 10-2: AMC MODULE EXTRACTION	73
TABLE 11-1: FRONT I/O PIN ASSIGNMENT.....	75

1 Product Description

The TAMC863 is a standard single-width AMC.1 compliant board with four high speed serial data communication channels. The TAMC863-10R provides a mid-size front panel and the TAMC863-11R provides a full-size front panel.

The serial communication controller is implemented in FPGA logic, along with the bus master capable PCI interface, guaranteeing long term availability and having the option to implement additional functions in the future.

Each channel provides a 512 DWORD (32 bit) receive FIFO and a transmit FIFO of up to 512 DWORD (32 bit) for high data throughput.

Data transfer is handled via TAMC863 initiated DMA cycles with minimum host/CPU intervention.

Several serial communication protocols are supported by each channel, such as asynchronous, isochronous, synchronous and HDLC mode.

A 14.7456 MHz oscillator provides standard asynchronous baud rates. A 24 MHz and a 10 MHz oscillator are provided for other (synchronous) baud rates.

Each channel provides various interrupt sources. The interrupt sources can be enabled or disabled individually.

Multiprotocol transceivers are used for the line interface. The physical interface is selectable by software, individually for each channel as EIA-232, EIA-422, EIA 449, EIA-530, EIA-530A, V.35, V.36 or X.21.

A 68 pin SCSI-V (VHDCI/Champ) type connector at the front panel provides access to the I/O lines.

The following signals are provided by the TAMC863 for each channel:

Receive Data (RxD +/-), Transmit Data (TxD +/-), Receive Clock (RxC +/-), Transmit Clock (TxC +/-), Ready-To-Send (RTS +/-), Clear-To-Send (CTS +/-), Carrier-Detect (CD +/-) and GND. Additionally serial channel 3 provides Data-Set-Ready (DSR3 +/-) and Data-Terminal-Ready (DTR3 +/-).

A serial EEPROM is used to store detailed board information and special configuration parameters.

Operating temperature range is -40°C to +85°C.

According to AMC.0, the TAMC863 provides an IPMI compliant Module Management Controller (MMC) with temperature monitoring and hot-swap support.

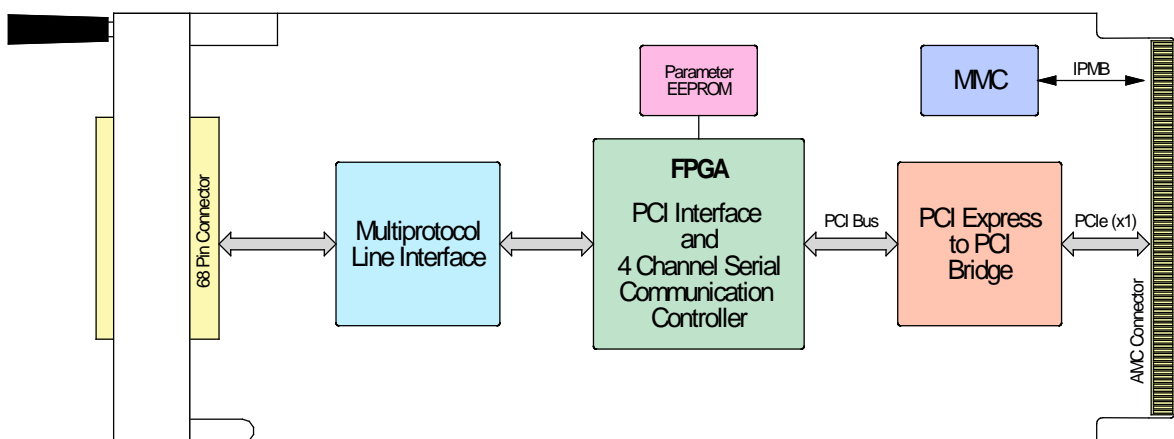

Figure 1-1 : Block Diagram

2 Technical Specification

AMC Interface	
Mechanical Interface	Advanced Mezzanine Card (AMC) Interface conforming to PICMG® AMC.0 R2.0 TAMC863-10R: Single, Mid-Size Module TAMC863-11R: Single, Full-Size Module
Electrical Interface	PICMG® AMC.1 R1.0 PCIe single lane (x1) port (AMC.1 Type 1 compliant)
IPMI	
IPMI Version	1.5
Front Panel LEDs (MMC controlled)	Blue Hot-Swap LED, Red Out-Of-Service/Failure LED (LED1), Green OK/Activity LED (LED 2)
On Board Devices	
PCI Express / PCI Bridge	PEX8112 (PLX Technology)
Serial Communication Controller (FPGA)	XC3S1500-4FG(G)320I Spartan-3 FPGA (Xilinx)
Serial Communication Interface	
Number of Channels	4
Line Transceivers	LTC1544/LTC1546 (Linear Technology) Multi-Protocol chip set, software selectable, on-chip cable termination (LTC1546)
FIFO	Main Transmit-FIFO per channel: up to 512 DWORD (2 Kbyte) Main Receive-FIFO per channel: 512 DWORD (2 Kbyte) SCC Transmit-FIFO per channel: up to 16 Byte SCC Receive-FIFO per channel: 16 Byte
Data Rates	Synchronous: 10 Mbit/s (V.11 Non-DPLL Modes), 2 Mbit/s (V.11 DPLL Modes) Asynchronous: 2 Mbit/s (V.11), 115.2 kbit/s (V.28)
I/O Connector	SCSI-V (VHDCI/champ) 68p
Physical Data	
Power Requirements	Management Power: 55mA typical @ +3.3V DC Payload Power: Typical 0.25A average, 0.45A peak @ +12V DC (all four channels set to no cable mode and connected) Typical 0.4A average, 0.8A peak @ +12V DC (all four channels set to E530A mode and connected) Typical 0.95A peak @ +12V DC (all four channels set to V.35 mode and connected)
Temperature Range	Operating -40°C - +85°C Storage -40°C - +85°C

MTBF	321.000 h MTBF values shown are based on calculation according to MIL-HDBK-217F and MIL-HDBK-217F Notice 2; Environment: G _B 20°C. The MTBF calculation is based on component FIT rates provided by the component suppliers. If FIT rates are not available, MIL-HDBK-217F and MIL-HDBK-217F Notice 2 formulas are used for FIT rate calculation.
Humidity	5 – 95 % non-condensing
Weight	92 g

Table 2-1 : Technical Specification

3 Handling and Operation Instructions

3.1 ESD Protection



The TAMC863 is sensitive to Electrostatic Discharge (ESD). Packing, unpacking and all other handling of the TAMC863 has to be done in an ESD/EOS protected Area.

4 On Board Devices

4.1 Overview

The DMA capable serial communication controller is implemented in an on board FPGA with integrated PCI bus interface (32 bit 33 MHz PCI bus).

The FPGA implements the serial communication controller logic and a register space and is the only accessible device on the TAMC863 PCI bus (except the PCIe/PCI bridge).

The PEX8112 (PLX Technology) PCIe/PCI bridge is used as the bridging device between the AMC PCIe interface and the on board PCI bus (i.e. the FPGA).

4.2 PEX8112 PCIe/PCI Bridge

The PEX8112 is a PCIe to PCI bridge. On the TAMC863 the PEX8112 is used in forward mode only.

4.2.1 PEX8112 Register Map

Register Group	PCI Space	Offset Address Range
PCI-Compatible Configuration (Type 1) Registers	PCI Express Configuration	0x00 - 0x3C
	Memory Mapped (BAR0)	
PCI-Compatible Extended Capability Registers for PCI Express Interface	PCI Express Configuration	0x40 - 0xFF
	Memory Mapped (BAR0)	
PCI Express Extended Capability Registers	PCI Express Configuration	0x100 - 0xFFFF
	Memory Mapped (BAR0)	
Main Control Registers	Memory Mapped (BAR0)	0x1000 - 0x1FFF

Table 4-1 : PEX8112 Register Map

4.2.2 PCI Express Configuration Space Register Mapping

4.2.2.1 PCI-Compatible Configuration (Type 1) Registers

PCI CFG Register Address	31	24	23	16	15	8	7	0	Read after initialization write access
0x00	PCI Device ID				PCI Vendor ID				8112 10B5
0x04	PCI Status				PCI Command				0010 0000
0x08	PCI Class Code						PCI Device Revision ID		060400 AA
0x0C	PCI Built-In Self- Test (Not Supported)	PCI Header Type		Internal PCI Bus Latency Timer		PCI Cache Line Size			00 01 00 00
0x10	PCI Base Address 0								0000000C
0x14	PCI Base Address 1								00000000
0x18	Secondary Latency Timer	Subordinate Bus Number		Secondary Bus Number		Primary Bus Number			00 00 00 00
0x1C	Secondary Status			I/O Limit		I/O Base			0200 00 00
0x20	Memory Limit			Memory Base					0000 0000
0x24	Prefetchable Memory Limit			Prefetchable Memory Base					0000 0000
0x28	Prefetchable Memory Base Upper 32 Bits								00000000
0x2C	Prefetchable Memory Limit Upper 32 Bits								00000000
0x30	I/O Limit Upper 16 Bits			I/O Base Upper 16 Bits					0000 0000
0x34	Reserved						PCI Capabilities Pointer		000000 40
0x38	PCI Base Address for Expansion ROM (Not Supported)								
0x3C	Bridge Control			Internal PCI Interrupt Wire		Internal PCI Interrupt Line			0000 01 00

Table 4-2 : PEX8112 PCI-Compatible Configuration (Type 1) Registers

4.2.2.2 PCI-Compatible Extended Capability Registers

PCI CFG Register Address	31	24	23	16	15	8	7	0	Read after initialization write access	
0x40	Power Management Capabilities				Power Management Next Capability Pointer		Power Management Capability ID		CA02 5001	
0x44	Power Management Data		Power Management Bridge Support		Power Management Control/Status					00 00 0000
0x48	Device-Specific Control								0000 0000	
0x4C	Reserved								-	
0x50	Message Signaled Interrupts Control				Message Signaled Interrupts Next Capability Pointer		Message Signaled Interrupts Capability ID		0080 60 05	
0x54	Message Signaled Interrupts Address								0000 0000	
0x58	Message Signaled Interrupts Upper Address								0000 0000	
0x5C	Reserved			Message Signaled Interrupts Data					0000 0000	
0x60	PCI Express Capabilities				PCI Express Next Capability Pointer		PCI Express Capability ID		0071 00 10	
0x64	Device Capabilities								0000 0000	
0x68	PCI Express Device Status			PCI Express Device Control					0000 2000	
0x6C	Link Capabilities								0000 4C11	
0x70	Link Status			Link Control					1011 0000	
0x74	Slot Capabilities								0000 0C80	
0x78	Slot Status			Slot Control					0400 0000	
0x7C	Reserved			Root Control					0000 0000	
0x80	Root Status								0000 0000	
0x84	Main Control Register Index								0000 0000	
0x88	Main Control Register Data								0000 0000	
0x8C - 0xFF	Reserved								-	

Table 4-3 : PEX8112 PCI-Compatible Extended Capability Registers

4.2.3 Configuration EEPROM

After reset, the PEX8112 loads initial configuration register data from an on board configuration EEPROM. Only register settings differing from default values are stored in the EEPROM.

For detailed information please refer to the PEX8112 manual.

Modifications are:

- Address Stepping is disabled (PCI Command Register)
- 66 MHz Capable bit is cleared (I/O Limit & Secondary Status Register)
- Slot Clock Configuration is enabled (Link Status/Control Register)
- PCI Express Enable & PCI Enable Bits are set (Device Initialization Register)

4.3 SCC FPGA

The Serial Communication Controller (SCC) FPGA resides on the on board 32 bit 33 MHz PCI bus and is the only other PCI device on the embedded PCI bus (PCI device number 0).

The FPGA implements a set of control & status registers as a PCI target, accessible in the PCI memory space.

The FPGA also implements a PCI DMA/Master engine used for the data transfers to and from host/system memory.

The FPGA configures from a serial Flash after power-up.

4.3.1 PCI Configuration Space

The SCC FPGA is assigned PCI device number 0 on the TAMC863 embedded PCI bus.

PCI Configuration Space Header				
Offset	31	16	15	0
0x00	Device ID (TAMC863: 0x835F)		Vendor ID (TEWS Technologies 0x1498)	
0x04	Status		Command	
0x08	Class Code (0x028000)			Rev ID
0x0C	BIST	Header Type (0x00)	Lat. Timer	Line Size
0x10	Base Address Register 0 Target register space of high speed serial communication controller (SCC FPGA)			
0x14	Base Address Register 1 (not used)			
0x18	Base Address Register 2 (not used)			
0x1C	Base Address Register 3 (not used)			
0x20	Base Address Register 4 (not used)			
0x24	Base Address Register 5 (not used)			
0x28	CardBus CIS Pointer (not used)			
0x2C	Subsystem ID (TAMC863-10R/-11R: 0x800A)		Subsystem Vendor ID (TEWS Technologies 0x1498)	
0x30	Expansion ROM Base Address (not used)			
0x34	Reserved			Cap. Pointer (0x00)
0x38	Reserved			
0x3C	Max_Lat (0x0A)	Min_Gnt (0x03)	Int_Pin (0x01)	Int_Line

Table 4-4 : PCI Configuration Space

5 Address Map

5.1 Register Space

The Register Space is accessible in the PCI Memory Space of the TAMC863 embedded PCI bus.

The Register Space Base address is found at PCI BAR0 (Offset 0x10) in the PCI Configuration Space of the SCC FPGA (PCI device number 0 on the TAMC863 embedded PCI bus)

PCI Device Number		0			
Device ID		0x835F (TAMC863)			
Vendor ID		0x1498 (TEWS Technologies)			
PCI Base Address (Offset in PCI Configuration Space)	PCI Space Mapping	Size (Byte)	Port Width (Bit)	Endian Mode	Description
0 (0x10)	MEM	2048	32	Little	Register Space

Table 5-1 : Register Space

5.2 Register Map

Offset to PCI Base Address	Addresses range	Number of used DWORD registers	Description
0x0000	0x0000...0x00FF	44 (0x0000...0x00EC)	Global Registers
0x0100	0x0100...0x017F	10 (0x0100...0x0158)	SCC0 Registers
0x0180	0x0180...0x01FF	10 (0x0180...0x01D8)	SCC1 Registers
0x0200	0x0200...0x027F	10 (0x0200...0x0258)	SCC2 Registers
0x0280	0x0280...0x02FF	10 (0x0280...0x02D8)	SCC3 Registers
0x0300	0x0300...0x07FF	0	(reserved)

Table 5-2 : Register Map

5.3 Global Register Map

All registers are 32 bit organized.

Offset to PCI Base Address	Register Name	
0x0000	GCMDR	Global Command Register
0x0004	GSTAR	Global Status Register
0x0008	GMODE	Global Mode Register
Interrupt Queue IQ specific registers (+ FIFO Control registers):		
0x000C	IQLENR0	IQ Length Register 0
0x0010	IQLENR1	IQ Length Register 1
0x0014	IQSCC0RXBAR	IQ SCC0 RX Base Address Register
0x0018	IQSCC1RXBAR	IQ SCC1 RX Base Address Register
0x001C	IQSCC2RXBAR	IQ SCC2 RX Base Address Register
0x0020	IQSCC3RXBAR	IQ SCC3 RX Base Address Register
0x0024	IQSCC0TXBAR	IQ SCC0 TX Base Address Register
0x0028	IQSCC1TXBAR	IQ SCC1 TX Base Address Register
0x002C	IQSCC2TXBAR	IQ SCC2 TX Base Address Register
0x0030	IQSCC3TXBAR	IQ SCC3 TX Base Address Register
0x0034	FIFO CR4	FIFO Control Register 4
0x0038	reserved	-
0x003C	IQCFG BAR	IQ CFG Base Address Register
0x0040	reserved	-
0x0044	FIFO CR1	FIFO Control Register 1
0x0048	reserved	-
0x004C	reserved	-
DMA Controller (DMAC) specific registers:		
0x0050	CH0CFG	Channel 0 Configuration Register
0x0054	CH0BRDA	Channel 0 Base Rx Descr. Address
0x0058	CH0BTDA	Channel 0 Base Tx Descr. Address
0x005C	CH1CFG	Channel 1 Configuration Register
0x0060	CH1BRDA	Channel 1 Base Rx Descr. Address
0x0064	CH1BTDA	Channel 1 Base Tx Descr. Address
0x0068	CH2CFG	Channel 2 Configuration Register
0x006C	CH2BRDA	Channel 2 Base Rx Descr. Address
0x0070	CH2BTDA	Channel 2 Base Tx Descr. Address
0x0074	CH3CFG	Channel 3 Configuration Register
0x0078	CH3BRDA	Channel 3 Base Rx Descr. Address
0x007C	CH3BTDA	Channel 3 Base Tx Descr. Address
0x0080...0x0097	reserved	-
0x0098	CH0FRDA	Channel 0 First Rx Descr. Address

Offset to PCI Base Address	Register Name	
0x009C	CH1FRDA	Channel 1 First Rx Descr. Address
0x00A0	CH2FRDA	Channel 2 First Rx Descr. Address
0x00A4	CH3FRDA	Channel 3 First Rx Descr. Address
0x00A8	reserved	-
0x00AC	reserved	-
0x00B0	CH0FTDA	Channel 0 First Tx Descr. Address
0x00B4	CH1FTDA	Channel 1 First Tx Descr. Address
0x00B8	CH2FTDA	Channel 2 First Tx Descr. Address
0x00BC	CH3FTDA	Channel 3 First Tx Descr. Address
0x00C0	reserved	-
0x00C4	reserved	-
0x00C8	CH0LRDA	Channel 0 Last Rx Descr. Address
0x00CC	CH1LRDA	Channel 1 Last Rx Descr. Address
0x00D0	CH2LRDA	Channel 2 Last Rx Descr. Address
0x00D4	CH3LRDA	Channel 3 Last Rx Descr. Address
0x00D8	reserved	-
0x00DC	reserved	-
0x00E0	CH0LTDA	Channel 0 Last Tx Descr. Address
0x00E4	CH1LTDA	Channel 1 Last Tx Descr. Address
0x00E8	CH2LTDA	Channel 2 Last Tx Descr. Address
0x00EC	CH3LTDA	Channel 3 Last Tx Descr. Address
Other registers:		
0x00F0	VR	Version Register
0x00F4	ISPR	ISP Register
0x00F8	GCTLR	Global Control Register
0x00FC...0x00FF	reserved	-

Table 5-3 : Global Register Map

5.4 SCC Register Map

The SCC registers are used to configure and control each of the four integrated Serial Communication Controller (SCC).

There is one complete SCC register set for each of the four SCC channels (0 ... 3).

The address of a certain SCC register is:

Register Space PCI Base Address + SCC Channel Offset + SCC Register Offset

Register Space PCI Base Address:

PCI Base Address 0

(Offset 0x10 in the PCI Configuration Space of the FPGA PCI Device)

SCC Channel Offset:

SCC0 (Channel 0): 0x0100

SCC1 (Channel 1): 0x0180

SCC2 (Channel 2): 0x0200

SCC3 (Channel 3): 0x0280

SCC Register Offset:

Register address offset, range 0x00 ... 0x5C (see SCC Register Map table)

Most registers and register bit positions are shared by all SCC protocol modes (HDLC, ASYNC). However the meaning (and name) of single bit positions might differ between different protocol modes. All registers are 32-bit organized registers.

Each SCC channel register set contains the following registers:

Register Offset	Register Name	
0x00	CMDR	Command Register
0x04	STAR	Status Register
0x08	CCR0	Channel Configuration Register 0
0x0C	CCR1	Channel Configuration Register 1
0x10	CCR2	Channel Configuration Register 2
0x14...0x2B	reserved	-
0x2C	BRR	Baud Rate Register
0x30...0x47	reserved	-
0x48	TCR	Termination Character Register
0x4C...0x53	reserved	-
0x54	IMR	Interrupt Mask Register
0x58	ISR	Interrupt Status Register
0x5C	ACR	Additional Configuration Register
0x60...0x7F	reserved	-

Table 5-4 : SCC Register Map

5.5 Global Registers

5.5.1 GCMR – Global Command Register (0x0000)

Bit	Symbol	Description	Access	Reset Value
31	CFGIQSCC3RX	<p>Configure Interrupt Queue SCC3 Receive Only valid, if action request bit 'AR' is set. The DMA (interrupt) controller will transfer interrupt vectors generated by the dedicated SCC receiver (3..0) to the corresponding interrupt queue which must be configured via 'CFGIQSCCiRX' command bits:</p> <p>'0': The DMA (interrupt) controller does NOT configure/re-configure the corresponding interrupt queue, if action request bit 'AR' is set to '1'.</p> <p>'1': Causes the DMA (interrupt) controller to configure/re-configure the corresponding interrupt queue, if action request bit 'AR' is set to '1'. Upon action request, the DMA (interrupt) controller will evaluate the corresponding interrupt queue base address and length registers which must have been programmed by software before.</p>	R/W	0
30	CFGIQSCC2RX	Configure Interrupt Queue SCC2 Receive (see above)	R/W	0
29	CFGIQSCC1RX	Configure Interrupt Queue SCC1 Receive (see above)	R/W	0
28	CFGIQSCC0RX	Configure Interrupt Queue SCC0 Receive (see above)	R/W	0

Bit	Symbol	Description	Access	Reset Value
27	CFGIQSCC3TX	<p>Configure Interrupt Queue SCC3 Transmit Only valid, if action request bit 'AR' is set. The DMA (interrupt) controller will transfer interrupt vectors generated by the dedicated SCC transmitter (3..0) to the corresponding interrupt queue which must be configured via 'CFGIQSCCiTX' command bits:</p> <p>'0': The DMA (interrupt) controller does NOT configure/re-configure the corresponding interrupt queue, if action request bit 'AR' is set to '1'.</p> <p>'1': Causes the DMA (interrupt) controller to configure the corresponding interrupt queue, if action request bit 'AR' is set to '1'.</p> <p>Upon action request, the DMA (interrupt) controller will evaluate the corresponding interrupt queue base address and length registers which must have been programmed by software before.</p>	R/W	0
26	CFGIQSCC2TX	Configure Interrupt Queue SCC2 Transmit (see above)	R/W	0
25	CFGIQSCC1TX	Configure Interrupt Queue SCC1 Transmit (see above)	R/W	0
24	CFGIQSCC0TX	Configure Interrupt Queue SCC0 Transmit (see above)	R/W	0
23:2 2	-	Reserved (0 for reads)	R	0
21	CFGIQCFG	<p>Configure Interrupt Queue Configuration Only valid, if action request bit 'AR' is set. The DMA (interrupt) controller will transfer action request acknowledge/failure interrupt vectors to the configuration interrupt queue which must be configured via 'CFGIQCFG' command bits:</p> <p>'0': The DMA (interrupt) controller does NOT configure/re-configure the configuration interrupt queue, if action request bit 'AR' is set to '1'.</p> <p>'1': Causes the DMA (interrupt) controller to configure the configuration interrupt queue, if action request bit 'AR' is set to '1'.</p> <p>Upon action request, the DMA (interrupt) controller will evaluate the configuration interrupt queue base address and length registers which must have been programmed by software before.</p>	R/W	0

Bit	Symbol	Description	Access	Reset Value
20:14	-	Reserved (0 for reads)	R	0
13	TXPR3	<p>Transmit Poll Request Channel 3</p> <p>Self-clearing command bit, only valid in 'HOLD' bit controlled DMA controller mode (bit CMODE = '0' in register GMODE):</p> <p>'0': No Transmit Poll Request is performed. The corresponding DMA controller transmit channel is stopped when HOLD='1' has been detected in the current transmit descriptor.</p> <p>'1': Setting this bit to '1', when HOLD='1' has been detected in the current transmit descriptor, will cause the controller to poll the 'HOLD' bit in the current transmit descriptor, i.e. the controller reads the configuration word (DWORD 0) and next descriptor address (DWORD 1) of the current descriptor again. If the 'HOLD' bit is detected cleared ('0'), the DMA controller will branch to the next descriptor. When the DMA controller is not in 'HOLD' state, this command is discarded.</p>	R/W	0
12	TXPR2	Transmit Poll Request Channel 2	R/W	0
11	TXPR1	Transmit Poll Request Channel 1	R/W	0
10	TXPR0	Transmit Poll Request Channel 0	R/W	0
9	IMAR	Interrupt Mask Action Request	R/W	1
8:1	-	Reserved (0 for reads)	R	0
0	AR	<p>Action Request</p> <p>Self-clearing command bit.</p> <p>'0': No action request</p> <p>'1': Action request</p> <p>Validates GCMDR CFGIQSCCiRX, CFGIQSCCiTX, CFGIQCFG register bits and CHiCFG RDR, RDT, IDR, IDT register bits.</p>	R/W	0

Table 5-5 : Global Command Register

5.5.2 GSTAR – Global Status Register (0x0004)

Status set by DMA Controller as an interrupt indication

The Global Status Register indicates whether an action request was executed successfully or not. It also gives information about the interrupt source and which interrupt queue has been written to when INTA# is activated.

Nine interrupt queues are provided:

- four receive interrupt vector queues (one for each SCCi, i=0...3)
- four transmit interrupt vector queues (one for each SCCi, i=0...3)
- one configuration interrupt vector queue (action request acknowledge/fail)

To clear a bit in the status register, the host CPU must write a '1' to the corresponding register bit. The PCI interrupt signal INTA# is asserted if any of the GSTAR interrupt indications bits is set. The PCI interrupt signal INTA# is de-asserted if all GSTAR Interrupt Indication bits are clear.

Bit	Symbol	Description	Access	Reset Value
31	IISCC3RX	Interrupt Indication Queue SCC3 Receive	R/C	0
30	IISCC2RX	Interrupt Indication Queue SCC2 Receive	R/C	0
29	IISCC1RX	Interrupt Indication Queue SCC1 Receive	R/C	0
28	IISCC0RX	Interrupt Indication Queue SCC0 Receive These bits indicate whether at least one new interrupt vector was transferred into the corresponding receive interrupt queue: '0': No new interrupt vector was transferred into the corresponding queue. '1': At least one new interrupt vector was transferred into the corresponding queue.	R/C	0
27	IISCC3TX	Interrupt Indication Queue SCC3 Transmit	R/C	0
26	IISCC2TX	Interrupt Indication Queue SCC2 Transmit	R/C	0
25	IISCC1TX	Interrupt Indication Queue SCC1 Transmit	R/C	0
24	IISCC0TX	Interrupt Indication Queue SCC0 Transmit These bits indicate whether at least one new interrupt vector was transferred into the corresponding transmit interrupt queue: '0': No new interrupt vector was transferred into the corresponding queue. '1': At least one new interrupt vector was transferred into the corresponding queue.	R/C	0
23:2 2	-	Reserved (0 for reads)	R	0

Bit	Symbol	Description	Access	Reset Value
21	IICFG	Interrupt Indication Configuration Queue These bits indicate whether at least one new interrupt vector was transferred into the configuration interrupt queue: '0': No new interrupt vector was transferred into the corresponding queue. '1': At least one new interrupt vector was transferred into the corresponding queue.	R/C	0
20:2	-	Reserved (0 for reads)	R	0
Action Request Result Status				
1	ARF	Action Request Failed Status This bit indicates that an action request command was completed with an 'action request failed' condition: '0': No action request was performed or no 'action request failed' condition occurred completing an action request. '1': The last action request command was completed with an 'action request failed' condition.	R/C	0
0	ARACK	Action Request Acknowledge Status This bit indicates that an action request command was completed successfully: '0': No action request was performed or completed successfully. '1': The last action request command was completed successfully.	R/C	0

Table 5-6 : Global Status Register

5.5.3 GMODE – Global Mode Register (0x0008)

Bit	Symbol	Description	Access	Reset Value
31:1	-	Reserved (0 for reads)	R	0
0	CMODE	DMA Control Mode '0' ' HOLD' bit control mode. The descriptor chain end condition is controlled via the 'HOLD' bit in each receive/transmit descriptor. '1' Last Receive/Transmit Descriptor Address mode. The descriptor chain end condition is controlled via registers LRDA/LTDA.	R/W	0

Table 5-7 : Global Mode Register

5.5.4 IQLENR0 – Interrupt Queue Length Register 0 (0x000C)

Bit	Symbol	Description	Access	Reset Value
31:2 8	IQSCC0RXLEN	Interrupt Queue SCC3 Receive Length	R/W	0
27:2 4	IQSCC1RXLEN	Interrupt Queue SCC2 Receive Length	R/W	0
23:2 0	IQSCC2RXLEN	Interrupt Queue SCC1 Receive Length	R/W	0
19:1 6	IQSCC3RXLEN	Interrupt Queue SCC0 Receive Length These bit fields determine the length of the corresponding receive interrupt queue (related to the respective SCC receive channel): Queue Length = (1 + 'IQSCCiRXLEN') * 32 DWORDS 'IQSCCiRXLEN' = 0...15	R/W	0
15:1 2	IQSCC0TXLEN	Interrupt Queue SCC3 Transmit Length	R/W	0
11:8	IQSCC1TXLEN	Interrupt Queue SCC2 Transmit Length	R/W	0
7:4	IQSCC2TXLEN	Interrupt Queue SCC1 Transmit Length	R/W	0
3:0	IQSCC3TXLEN	Interrupt Queue SCC0 Transmit Length These bit fields determine the length of the corresponding transmit interrupt queue (related to the respective SCC transmit channel): Queue Length = (1 + 'IQSCCiTXLEN') * 32 DWORDS, 'IQSCCiTXLEN' = 0...15	R/W	0

Table 5-8 : Interrupt Queue Length Register 0

5.5.5 IQLENR1 – Interrupt Queue Length Register 1 (0x0010)

Bit	Symbol	Description	Access	Reset Value
31:2 4	-	Reserved (0 for reads)	R	0
23:2 0	IQCFGLEN	Interrupt Queue Configuration Length Queue Length = (1 + 'IQCFGLEN') * 32 DWORDS, 'IQCFGLEN' = 0...15	R/W	0
19:0	-	Reserved (0 for reads)	R	0

Table 5-9 : Interrupt Queue Length Register 1

5.5.6 IQSCCiRXBAR – Interrupt Queue SCCi Receiver Base Address Register (i=0...3) (0x0014, 0x0018, 0x001C, 0x0020)

Bit	Symbol	Description	Access	Reset Value
31:2	IQSCCiRXBAR	PCI Base Address of Receive Interrupt Queue	R/W	0
1:0			R	0

Table 5-10: IQSCCiRXBAR Register

5.5.7 IQSCCiTXBAR – Interrupt Queue SCCi Transmitter Base Address Register (i=0...3) (0x0024, 0x0028, 0x002C, 0x0030)

Bit	Symbol	Description	Access	Reset Value
31:2	IQSCCiTXBAR	PCI Base Address of Transmit Interrupt Queue	R/W	0
1:0			R	0

Table 5-11: IQSCCiTXBAR Register

5.5.8 FIFO CR4 – FIFO Control Register 4 (0x0034)

Bit	Symbol	Description	Access	Reset Value
31:24	TFFTHRES3	Transmit FIFO Forward Threshold Channel 3	R/W	0
23:16	TFFTHRES2	Transmit FIFO Forward Threshold Channel 2	R/W	0
15:8	TFFTHRES1	Transmit FIFO Forward Threshold Channel 1	R/W	0
:0	TFFTHRES0	<p>Transmit FIFO Forward Threshold Channel 0</p> <p>These bit fields determine the channel specific Transmit FIFO Forward Threshold for the corresponding channel <i>i</i> in number of DWORDs. This threshold controls DMAC operation towards the serial channels (SCCi).</p> <p>As soon as the number of valid data words (belonging to a frame) in the main transmit FIFO is greater than the threshold, the DMAC will provide transmit data to the corresponding SCC. Once having started serving data for a frame, the DMAC will ignore this threshold providing all available data of the current frame to the SCC. Threshold operation starts again with the next frame. Frames shorter than the threshold will be transferred as soon as a frame end indication is detected by the DMAC.</p> <p><i>Note: Programming TFFTHRES_i to zero will disable the threshold causing the DMAC to transfer all data immediately. This may be useful for not frame oriented data transmission, e.g. in ASYNC protocol mode.</i></p>	R/W	0

Table 5-12 : FIFO Control Register 4

5.5.9 IQCFGBAR – Interrupt Queue Configuration Base Address Register (0x003C)

Bit	Symbol	Description	Access	Reset Value
31:2	IQCFGBAR	PCI Base Address of Configuration Interrupt Queue	R/W	0
1:0			R	0

Table 5-13: IQCFGBAR Register

5.5.10 FIFO CR1 – FIFO Control Register 1 (0x0044)

Bit	Symbol	Description	Access	Reset Value																		
31:27	-	Reserved (0 for reads)	R	0																		
26:24	TFSIZE3	Main Transmit-FIFO Size (Depth) Channel 3	R/W	111																		
23:19	-	Reserved (0 for reads)	R	0																		
18:16	TFSIZE2	Main Transmit-FIFO Size (Depth) Channel 2	R/W	111																		
15:9	-	Reserved (0 for reads)	R	0																		
10:8	TFSIZE1	Main Transmit-FIFO Size (Depth) Channel 1	R/W	111																		
7:3	-	Reserved (0 for reads)	R	0																		
2:0	TFSIZE0	Main Transmit-FIFO Size (Depth) Channel 0 Main Transmit-FIFO Size (Depth) is $2^{\text{power}(TFSIZE_i + 2)}$ <table border="1" data-bbox="673 1178 1206 1591" style="margin: 10px auto;"> <thead> <tr> <th>TFSIZE_i</th> <th>FIFO Size (Depth) in DWords (4 Bytes)</th> </tr> </thead> <tbody> <tr><td>111</td><td>512</td></tr> <tr><td>110</td><td>256</td></tr> <tr><td>101</td><td>128</td></tr> <tr><td>100</td><td>64</td></tr> <tr><td>011</td><td>32</td></tr> <tr><td>010</td><td>16</td></tr> <tr><td>001</td><td>8</td></tr> <tr><td>000</td><td>4</td></tr> </tbody> </table>	TFSIZE _i	FIFO Size (Depth) in DWords (4 Bytes)	111	512	110	256	101	128	100	64	011	32	010	16	001	8	000	4	R/W	111
TFSIZE _i	FIFO Size (Depth) in DWords (4 Bytes)																					
111	512																					
110	256																					
101	128																					
100	64																					
011	32																					
010	16																					
001	8																					
000	4																					

Table 5-14: FIFO Control Register 1

5.5.11 CHiCFG – Channel i Configuration Register (i=0...3) (0x0050, 0x005C, 0x0068, 0x0074)

Bit	Symbol	Description	Access	Reset Value
31:28	-	Reserved (0 for reads)	R	0
27	MRFI	<p>Mask Receive FI Interrupt (Channel i) This bit enables/disables the receive FI interrupt indication for the DMA channel, the register is dedicated to (i=3..0):</p> <p>'0': FI interrupt generation is enabled for the dedicated DMA receive channel.</p> <p>'1': FI interrupt generation is disabled for the dedicated DMA receive channel.</p>	R/W	0
26	MTFI	<p>Mask Transmit FI Interrupt (Channel i) This bit enables/disables the transmit FI interrupt indication for the DMA channel, the register is dedicated to (i=3..0):</p> <p>'0': FI interrupt generation is enabled for the dedicated DMA transmit channel.</p> <p>'1': FI interrupt generation is disabled for the dedicated DMA transmit channel.</p>	R/W	0
25	MRERR	<p>Mask Receive ERR Interrupt (Channel i) This bit enables/disables the receive ERR interrupt indication for the DMA channel, the register is dedicated to (i=3..0):</p> <p>'0': ERR interrupt generation is enabled for the dedicated DMA receive channel.</p> <p>'1': ERR interrupt generation is disabled for the dedicated DMA receive channel.</p>	R/W	0
24	MTERR	<p>Mask Transmit ERR Interrupt (Channel i) This bit enables/disables the transmit ERR interrupt indication for the DMA channel, the register is dedicated to (i=3..0):</p> <p>'0': ERR interrupt generation is enabled for the dedicated DMA transmit channel.</p> <p>'1': ERR interrupt generation is disabled for the dedicated DMA transmit channel.</p>	R/W	0
23	-	Reserved (0 for reads)	R	0

Bit	Symbol	Description	Access	Reset Value
22	RDR	<p>Reset DMA Receiver (Channel i) Must be validated by the Action Request bit in the GCMR. Cleared automatically if successful.</p> <p>This command resets the specific DMA controller receive channel and also flushes the receive data FIFO. After reset, the respective DMA channel is in its initial state equal to the reset state after power on. The receive data FIFO will not accept any receive data until the IDR command is successfully finished.</p>	R/W	0
21	RDT	<p>Reset DMA Transmitter (Channel i) Must be validated by the Action Request bit in the GCMR. Cleared automatically if successful.</p> <p>This command resets the specific DMA controller transmit channel. After reset, the respective DMA channel is in its initial state equal to the reset state after power on.</p>	R/W	0
20	IDR	<p>Initialize DMA Receiver (Channel i) Must be validated by the Action Request bit in the GCMR. Cleared automatically if successful.</p> <p>This command causes the specific DMA receive channel to fetch the base descriptor address from register CHiBRDA and to branch to the corresponding descriptor. Afterwards normal DMA operation on the receive descriptor list is performed depending on the selected DMA control mode.</p> <p><i>Note: To avoid unexpected DMA controller behavior, it is recommended to apply 'IDR' command only, if the specific DMA channel is in reset state.</i></p>	R/W	0
19	IDT	<p>Initialize DMA Transmitter (Channel i) Must be validated by the Action Request bit in the GCMR. Cleared automatically if successful.</p> <p>This command causes the specific DMA transmit channel to fetch the base descriptor address from register CHiBTDA and to branch to the corresponding descriptor. Afterwards normal DMA operation on the transmit descriptor list is performed depending on the selected DMA control mode.</p> <p><i>Note: To avoid unexpected DMA controller behavior, it is recommended to apply 'IDT' command only, if the specific DMA channel is in reset state.</i></p>	R/W	0
18:0	-	Reserved (0 for reads)	R	0

Table 5-15: CHICFG Register

5.5.12 CHiBRDA – Channel i Base Receive Descriptor Address Register (i=0...3) (0x0054, 0x0060, 0x006C, 0x0078)

Bit	Symbol	Description	Access	Reset Value
31:2	CHiBRDA	PCI Base Address of Receive Descriptor	R/W	0
1:0			R	0

Table 5-16: CHiBRDA Register

5.5.13 CHiBTDA – Channel i Base Transmit Descriptor Address Register (i=0...3) (0x0058, 0x0064, 0x0070, 0x007C)

Bit	Symbol	Description	Access	Reset Value
31:2	CHiBTDA	PCI Base Address of Transmit Descriptor	R/W	0
1:0			R	0

Table 5-17: CHiBTDA Register

5.5.14 CHiFRDA – Channel i First (Current) Receive Descriptor Address Register (i=0...3) (0x0098, 0x009C, 0x00A0, 0x00A4)

Bit	Symbol	Description	Access	Reset Value
31:2	CHiFRDA	DMAC enters the PCI Base Address of the current Receive Descriptor	R	0
1:0			R	0

Table 5-18: CHiFRDA Register

5.5.15 CHiFTDA – Channel i First (Current) Transmit Descriptor Address Register (i=0...3) (0x00B0, 0x00B4, 0x00B8, 0x00BC)

Bit	Symbol	Description	Access	Reset Value
31:2	CHiFTDA	DMAC enters the PCI Base Address of the current Transmit Descriptor	R	0
1:0			R	0

Table 5-19: CHiFTDA Register

5.5.16 CHiLRDA – Channel i Last Receive Descriptor Address Register (i=0...3) (0x00C8, 0x00CC, 0x00D0, 0x00D4)

Bit	Symbol	Description	Access	Reset Value
31:2	CHiLRDA	PCI Base Address of Last Receive Descriptor	R/W	0

1:0			R	0
-----	--	--	---	---

Table 5-20: CHILRDA Register

5.5.17 CHILTDA – Channel i Last Transmit Descriptor Address Register (i=0...3) (0x00E0, 0x00E4, 0x00E8, 0x00EC)

Bit	Symbol	Description	Access	Reset Value
31:2	CHILTDA	PCI Base Address of Last Transmit Descriptor	R/W	0
1:0			R	0

Table 5-21: CHILTDA Register

5.5.18 VR – Version Register (0x00F0)

Bit	Symbol	Description	Access	Reset Value
31:1 6	SPC_ID	Reserved (0 for reads) or special customer ID register	R	0
15:0	VER	FPGA Logic Version	R	0x0005

Table 5-22: Version Register

5.5.19 ISPR – In-System-Programming Register (0x00F4)

This register is reserved for (factory) reprogramming of the FPGA configuration flash.
 No write accesses shall be done to this address, as permanent damage may occur.

5.5.20 GCTLR – Global Control Register (0x00F8)

Bit	Symbol	Description	Access	Reset Value
31:2 0	-	Reserved (0 for reads)	R	0
19	EEDO	Serial EEPROM Data Out (Q)	R	-
18	EEDI	Serial EEPROM Data In (D)	R/W	0
17	EECS	Serial EEPROM Chip Select (S)	R/W	0
16	EESK	Serial EEPROM Clock (C)	R/W	0
15:8	RETRYCNT	Maximum number of retries, that occurred during a PCI transaction	R	0x00
7	RCNTCLR	Reset maximum number of retries Self-clearing command bit	R/W	0
6	INI_HALT	Initiator State Machine is stopped due to PCI transaction abort	R	0
5	INI_REL	Release the stopped Initiator State Machine Self-clearing command bit	R/W	0
4:1	-	Reserved	R	0
0	LRST	Local Reset Self-clearing command bit. The complete local part of the device is reset. Only the registers in the PCI configuration space keep their values.	R/W	0

Table 5-23: Global Control Register

5.6 SCC Channel Specific Registers

5.6.1 CMDR – Command Register (0x0100, 0x0180, 0x0200, 0x0280)

Bit	Symbol	Description	Access	Reset Value
31:2 5	-	Reserved (0 for reads)	R	0
24	XRES	Transmitter Reset (Self-clearing) '1': The transmit FIFOs (Main and SCC FIFO) are cleared and the transmitter protocol engines are reset to their initial state. A transmitter reset command is recommended after all changes in protocol mode configurations (e.g. switching between the protocol engines HDLC/ASYNC or sub-modes of HDLC). <i>Note: A transmit clock must be present.</i>	R/W	0
23:1 7	-	Reserved (0 for reads)	R	0
16	RRES	Receiver Reset (Self-clearing) '1': The receive SCC FIFO is flushed and the receiver protocol engine is reset. Recommended after changes in protocol configuration (switching between the protocol engines or sub-modes of HDLC). <i>Note: A receive clock must be present.</i>	R/W	0
15:0	-	Reserved (0 for reads)	R	0

Table 5-24: Command Register

5.6.2 STAR – Status Register (0x0104, 0x0184, 0x0204, 0x0284)

Bit	Symbol	Description	Access	Reset Value
31:25	-	Reserved (0 for reads)	R	0
24	CTS	<p>Clear To Send Input Signal State</p> <p>'0': CTS# input signal is inactive (high level)</p> <p>'1': CTS# input signal is active (low level)</p> <p><i>Note: A transmit clock must be present. Optionally this input can be programmed to generate an interrupt on signal level changes.</i></p>	R	-
23:22	-	Reserved (0 for reads)	R	0
21	CD	<p>CD (Carrier Detect) Input Signal State</p> <p>'0': CD input signal is inactive (low level)</p> <p>'1': CD input signal is active (high level)</p> <p><i>Note: A receive clock must be present. Optionally this input can be programmed to generate an interrupt on signal level changes.</i></p>	R	-
20	-	Reserved (0 for reads)	R	0
19	DPLA	<p>DPLL Asynchronous</p> <p>This bit is only valid if the receive clock is recovered by the DPLL and FM0, FM1 or Manchester data encoding is selected. It is set when the DPLL has lost synchronization. In this case reception is disabled until synchronization has been regained. In addition transmission is interrupted in all cases where transmit clock is derived from the DPLL.</p> <p>'0' DPLL is synchronized.</p> <p>'1' DPLL is asynchronous (re-synchronization process is started automatically).</p>	R	-
18:1	-	Reserved (0 for reads)	R	0
0	DSR3	Data Set Ready Channel 3 (Only on channel 3!)	R	-

Table 5-25: Status Register

5.6.3 CCR0 – Channel Configuration Register 0 (0x0108, 0x0188, 0x0208, 0x0288)

Bit	Symbol	Description	Access	Reset Value
31:23	-	Reserved (0 for reads)	R	0
22:20	SC	Serial Port Configuration '000': NRZ data encoding '010': NRZI data encoding '100': FM0 data encoding '101': FM1 data encoding '110': Manchester data encoding others: reserved	R/W	000
19:18	-	Reserved (0 for reads)	R	0
17:16	SM	Serial Port Mode Selects the protocol engine: '00': HDLC synchronous '01': reserved '10': reserved '11': Asynchronous	R/W	00
15:13	-	Reserved (0 for reads)	R	0
12	VIS	Masked Interrupts Visible '0': Masked interrupt status bits are not visible on interrupt status register (ISR) read accesses. '1': Masked interrupt status bits are visible in the ISR. To clear these interrupt flags, the host CPU must write '1' to the corresponding ISR bit. <i>Note: Masked interrupts will not generate an interrupt vector to the interrupt controller.</i>	R/W	0
11:8	-	Reserved (0 for reads)	R	0
7	BCR	Bit Clock Rate (async/isochr) '0': Isochronous (Bit Clock Rate x1). I.e. Asynchronous without oversampling. Transmitter/Receiver Clock Rate is Data Bit Rate x1. Bits are sampled once. '1': Standard asynchronous (Bit Clock Rate x16). I.e. Asynchronous with 16x oversampling. Transmitter/Receiver Clock Rate is Data Bit Rate x16. Bits are sampled 16 times. The result is determined by a majority decision of 3 samples around the bit center. NRZ encoding has to be selected.	R/W	0

Bit	Symbol	Description	Access	Reset Value
6	-	Reserved (0 for reads)	R	0
5	TOE	Transmit Clock Out Enable '0': TxC is input (DCE mode) '1': TxC is output (DTE# mode) <i>Note: The Transceiver direction of TxC is set according to TOE.</i>	R/W	0
4:0	-	Reserved (0 for reads)	R	0

Table 5-26: Channel Configuration Register 0

5.6.4 CCR1 –Configuration Register 1 (0x010C, 0x018C, 0x020C, 0x028C)

Bit	Symbol	Description	Access	Reset Value															
31:2 1	-	Reserved (0 for reads)	R	0															
20	RTS	Request To Send pin control (async./isochr.) The request to send pin RTS# can be controlled as an output autonomously or via setting/clearing bit 'RTS'. '0': Pin RTS# (output) is controlled autonomously. The behavior of this pin depends on bit 'FRTS'. '1': Pin RTS# can be controlled by software. The output level of this pin depends on bit 'FRTS'.	R/W	0															
19	FRTS	Flow Control (RTS) Function of RTS# depends on 'RTS' and 'FRTS'. <table border="1" style="margin-left: 20px; border-collapse: collapse;"> <thead> <tr> <th>RTS</th> <th>FRTS</th> <th></th> </tr> </thead> <tbody> <tr> <td>0</td> <td>0</td> <td>Pin RTS# is controlled autonomously. RTS is asserted (low) when data is available in the SCC transmit FIFO.</td> </tr> <tr> <td>0</td> <td>1</td> <td>Pin RTS# is controlled autonomously. RTS is asserted (low) if the SCC receive FIFO data-count drops below 4 bytes, and de-asserted (high) if the SCC receive FIFO data-count reaches 12 bytes.</td> </tr> <tr> <td>1</td> <td>0</td> <td>Forces RTS# to low (asserted).</td> </tr> <tr> <td>1</td> <td>1</td> <td>Forces RTS# to high (de-asserted).</td> </tr> </tbody> </table> <i>Note: A transmit clock is necessary. In HDLC mode the RTS pin is always controlled by software (FRTS bit).</i>	RTS	FRTS		0	0	Pin RTS# is controlled autonomously. RTS is asserted (low) when data is available in the SCC transmit FIFO.	0	1	Pin RTS# is controlled autonomously. RTS is asserted (low) if the SCC receive FIFO data-count drops below 4 bytes, and de-asserted (high) if the SCC receive FIFO data-count reaches 12 bytes.	1	0	Forces RTS# to low (asserted).	1	1	Forces RTS# to high (de-asserted).	R/W	0
RTS	FRTS																		
0	0	Pin RTS# is controlled autonomously. RTS is asserted (low) when data is available in the SCC transmit FIFO.																	
0	1	Pin RTS# is controlled autonomously. RTS is asserted (low) if the SCC receive FIFO data-count drops below 4 bytes, and de-asserted (high) if the SCC receive FIFO data-count reaches 12 bytes.																	
1	0	Forces RTS# to low (asserted).																	
1	1	Forces RTS# to high (de-asserted).																	

Bit	Symbol	Description	Access	Reset Value
18	FCTS	<p>Flow Control (CTS) (async./isochr.)</p> <p>'0': Transmitter is stopped, if CTS# input signal is inactive (high) and enabled if asserted (low). In ASYNC mode, the current byte is completely sent even if CTS# becomes inactive during transmission.</p> <p>'1': Transmitter is always enabled.</p> <p><i>Note: In ASYNC mode the current byte is completely sent, even if CTS# becomes deasserted during transmission.</i></p>	R/W	0
17:1 6	-	Reserved (0 for reads)	R	0
15:1 4	MDS	<p>Mode Select (hdlc)</p> <p>Selects the HDLC sub mode.</p> <p>'00': reserved</p> <p>'01': reserved</p> <p>'10': Address Mode 0</p> <p>'11': Extended transparent mode (bit transparent transmission/reception)</p>	R/W	00
13:9	-	Reserved (0 for reads)	R	0
8	TLP	<p>Test Loop</p> <p>The test loop is closed at the far end of serial transmit and receive line just before the respective TxD and RxD pins:</p> <p>'0': Test loop disabled.</p> <p>'1': Test loop enabled.</p>	R/W	0
7	TOIE	<p>Time Out Indication Enable (async./isochr.)</p> <p>A 'block end' indication is inserted in the receive FIFO if a time out occurs. The current receive descriptor will be finished.</p> <p>'0': Time Out function disabled.</p> <p>'1': Time Out function enabled:</p> <p><i>Note: A time out event will generate a 'TIME' interrupt (if unmasked).</i></p>	R/W	0
6:0 (asyn)	TOLEN	<p>Time Out Length (async./isochr.)</p> <p>Determines the time out period. If there is no receive line activity for the configured period of time, a time out indication is generated if enabled via bit 'TOIE'.</p> <p>The period of time is programmable in multiples of a <u>single</u> character frame length (CFL) time equivalents including start, parity and stop bits:</p> $T_{\text{TOUIT}} = (\text{TOLEN} + 1) * 1 * \text{CFL}$	R/W	0

Bit	Symbol	Description	Access	Reset Value
1 (hdlc)	CRL	<p>CRC Reset Value (hdlc)</p> <p>Defines the initial value of the CRC generators:</p> <p>'0': Initial value is 0xFFFF (16 bit CRC), 0xFFFFFFFF (32 bit CRC); (default value for most HDLC applications)</p> <p>'1': Initial value is 0x0000 (16 bit CRC), 0x00000000 (32 bit CRC).</p>	R/W	0
0 (hdlc)	C32	<p>CRC-32 Select (hdlc)</p> <p>This bit enables 32-bit CRC operation for transmit and receive.</p> <p>'0': 16-bit CRC generation/checking.</p> <p>'1': 32-bit CRC generation/checking.</p> <p>CRC-16 Polynom used is $x^{16} + x^{12} + x^5 + 1$.</p> <p>CRC-32 Polynom used is $x^{32} + x^{26} + x^{23} + x^{22} + x^{16} + x^{12} + x^{11} + x^{10} + x^8 + x^7 + x^5 + x^4 + x^2 + x + 1$</p>	R/W	0

Table 5-27: Channel Configuration Register 1

5.6.5 CCR2 – Channel Configuration Register 2 (0x0110, 0x0190, 0x0210, 0x0290)

Bit	Symbol	Description	Access	Reset Value
31:3 0	-	Reserved (0 for reads)	R	0
29:2 8 (asyn.)	CHL	Character Length (asynch./isochr.) '00': 8 bit data '01': 7 bit data '10': 6 bit data '11': 5 bit data	R/W	00
27	RAC	Receiver active '0': Receiver inactive, receive line is ignored. '1': Receiver active.	R/W	0
26	-	Reserved (0 for reads)	R	0
25 (asyn.)	XBRK	Transmit Break (asynch./isochr.) '0': Normal transmit operation '1': Forces the TxD pin to 'low' level immediately (break condition), regardless of any character being currently transmitted. This command is executed immediately with the next rising edge of the transmit clock and further transmission is disabled. The currently sent character is lost. Data stored in the SCC transmit FIFO will be sent as soon as the break condition is cleared (XBRK='0'). A transmit reset command (bit 'XRES' in register CMDR) does NOT clear the break condition automatically.	R/W	0
24 (asyn.)	STOP	Stop Bit Number (asynch./isochr.) '0': 1 stop bit per character '1': 2 stop bits per character	R/W	0
23:2 2 (asyn.)	PAR	Parity Format (asynch./isochr.) '00': Space ('0') is inserted as parity bit '01': Odd parity '10': Even parity '11': Mark ('1') is inserted as parity bit <i>Note: The received parity bit (and parity error) is stored in the receive buffer if bit 'RFDF' = '1'.</i>	R/W	0
21 (asyn.)	PARE	Parity Enable (asynch./isochr.) '0': Parity generation/checking is disabled. '1': Parity generation/checking is enabled.	R/W	0

Bit	Symbol	Description	Access	Reset Value										
24:23 (hdlc)	-	Reserved (0 for reads)	R	0										
22 (hdlc)	DRCRC	<p>Disable Receive CRC Checking (hdlc)</p> <p>'0': The receiver expects a 16 or 32 bit CRC within a HDLC frame.</p> <p>'1': The receiver does not expect a CRC.</p> <p><i>Note: A received checksum (2 or 4 bytes) is always forwarded to the receive buffer as data.</i></p>	R/W	0										
21 (hdlc)	-	Reserved (0 for reads)	R	0										
20	-	Reserved (0 for reads)	R	0										
19	RFDF	<p>Receive FIFO Data Format (async./isochr.)</p> <p>'0': No additional status information stored.</p> <p>'1': Status byte is stored after each data byte to the receive buffer:</p> <table border="1" style="margin-left: auto; margin-right: auto;"> <tr> <td style="text-align: center;">15</td> <td style="text-align: center;">14</td> <td style="text-align: center;">13...9</td> <td style="text-align: center;">8</td> <td style="text-align: center;">7.....0</td> </tr> <tr> <td style="text-align: center;">parity error</td> <td style="text-align: center;">frame error</td> <td style="text-align: center;">reserved</td> <td style="text-align: center;">parity bit</td> <td style="text-align: center;">data byte</td> </tr> </table> <p><i>Note: RFDF value is only evaluated while Receiver Reset 'RRES' is active.</i></p>	15	14	13...9	8	7.....0	parity error	frame error	reserved	parity bit	data byte	R/W	0
15	14	13...9	8	7.....0										
parity error	frame error	reserved	parity bit	data byte										
18	RFTH	<p>Receive FIFO Threshold</p> <p>'0': Maximum PCI bus write burst length for receive data is set to 15 DWORDs (gather receive data for PCI bus bursts).</p> <p>'1': Maximum PCI bus write burst length for receive data is set to 1 DWORD (forward receive data to the PCI bus as soon as possible).</p>	R/W	0										
17:4	-	Reserved (0 for reads)	R	0										
3	ITF	<p>Interframe Time Fill (hdlc)</p> <p>This bit selects the idle state of the transmit pin TxD:</p> <p>'0': Continuous logical '1' is sent during idle phase.</p> <p>'1': Continuous flag sequences are sent ('01111110' flag pattern).</p>	R/W	0										
2:1	-	Reserved (0 for reads)	R	0										
0 (hdlc)	XCRC	<p>Transmit CRC Checking Mode (hdlc)</p> <p>'0': The transmit checksum (2 or 4 bytes) is generated and appended to the transmit data.</p> <p>'1': The transmit checksum is not generated.</p>	R/W	0										

Table 5-28: Channel Configuration Register 2

5.6.6 BRR – Baud Rate Register (0x012C, 0x01AC, 0x022C, 0x02AC)

Bit	Symbol	Description	Access	Reset Value
31	BRGM	BRG Mode	R/W	0
30:2 1	-	Reserved (0 for reads)	R	0
20:0	BRD	Baud Rate Divisor	R/W	0

Table 5-29: Baud Rate Register

These values determine the divisor of the baud rate generator. The baud rate generator input clock f_{in} depends on the selected clock source (see also chapters “Clock Sources” and “ACR - Additional Configuration Register”).

The resulting output frequency of the baud rate generator is:

$$f_{BRG} = f_{in} / k$$

The divisor k can be set in 2 ways, determined by BRR[31].

When BRR[31] = 0, k is calculated as follows:

$$k = (N + 1) \times 2^M$$

$$\text{with } N \text{ (BRR[5:0])} = 0..63 \text{ and } M \text{ (BRR[11:8])} = 0..15$$

The alternative is to set $(k - 1)$ directly as a 21-bit wide value, when BRR[31] = 1:

$$k = \text{BRR[20:0]} + 1 \quad (\text{respectively } \text{BRR[20:0]} = k - 1)$$

5.6.7 TCR – Termination Character Register (0x0148, 0x01C8, 0x0248, 0x02C8)

Bit	Symbol	Description	Access	Reset Value
31:1 6	-	Reserved (0 for reads)	R	0
15	TCDE	Termination Character Detection Enable (async./isochr.) '0': No receive termination character detection '1': Termination character detection is enabled. The receive data is analyzed for the termination character TC. When character is detected, a 'block end' and a 'TCDI' interrupt (if enabled) is generated.	R/W	0
14:8	-	Reserved (0 for reads)	R	0
7:0	TC	Termination Character (async./isochr.) Defines the termination character which is monitored on the receive data stream if enabled via bit 'TCDE'.	R/W	0

Table 5-30: Termination Character Register

5.6.8 IMR – Interrupt Mask Register (0x0154, 0x01D4, 0x0254, 0x02D4)

Bit	Symbol	Description	Access	Reset Value
31:19	-	'0': interrupt is NOT masked, interrupt is generated via INTA# '1': interrupt is masked, no interrupt generation on INTA# See Interrupt Status Register for interrupt bit description.	R	1
18	ALLS		R/W	1
17	-		R	1
16 (hdlc)	XDU		R/W	1
16 (asyn)	-		R	1
15	-		R	1
14	CSC		R/W	1
13:10	-		R	1
9 (asyn)	BRK		R/W	1
8 (asyn)	BRKT		R/W	1
7 (asyn)	TCD		R/W	1
6 (asyn)	TIME		R/W	1
5 (asyn)	PERR		R/W	1
4 (asyn)	FERR		R/W	1
9:4 (hdlc)	-		R	1
3	PLLA		R/W	1
2	CDSC		R/W	1
1	RFO	R/W	1	
0	-	R	1	

Table 5-31: Interrupt Mask Register

Unused interrupts shall be masked to avoid unwanted behavior.

Especially CSC and CDSC should be masked if CTS and CD inputs are unconnected.

5.6.9 ISR – Interrupt Status Register (0x0158, 0x01D8, 0x0258, 0x02D8)

Bit	Symbol	Description	Access	Reset Value
31:19	-	Reserved (0 for reads)	R	0
18	ALLS	<p>ALL Sent Interrupt</p> <p>HDLC Mode: This bit is set to '1' if the last bit of the current HDLC frame is sent out via pin TxD,</p> <p>ASYNC/ISOCHR Mode: This bit is set to '1', if the last character is completely sent via pin TxD and no further data is stored in the SCC transmit FIFO, i.e. the transmit FIFO is empty.</p>	R/C	0
17	-	Reserved (0 for reads)	R	0
16 (hdlc)	XDU	<p>Transmit Data Underrun Interrupt (hdlc)</p> <p>HDLC Mode: This bit is set to '1', if the current frame was terminated by the SCC with an abort sequence, because neither a 'frame end / block end' indication was detected in the FIFO (to complete the current frame) nor more data is available in the SCC transmit FIFO.</p> <p><i>Note: The transmitter is stopped if this condition occurs and needs to be reset via command bit 'XRES' in register CMDR.</i></p>	R/C	0
16 (asyn)	-	Reserved (0 for reads)	R	0
15	-	Reserved (0 for reads)	R	0
14	CSC	<p>CTS# Status Change Interrupt</p> <p>This bit is set to '1', if a transition occurs on signal CTS#. The current state of signal CTS# is monitored by status bit 'CTS' in status register STAR.</p>	R/C	0
13:10	-	Reserved (0 for reads)	R	0
9 (asyn)	BRK	<p>Break Interrupt (asyn./isochr.)</p> <p>This bit is set to '1', if a break condition was detected on the receive line, i.e. a low level for a time equal to (character length + parity bit + stop bit(s)) bits depending on the selected ASYNC character format.</p>	R/C	0
8 (asyn)	BRKT	<p>Break Terminated Interrupt (asyn./isochr.)</p> <p>This bit is set to '1', if a previously detected break condition on the receive line is terminated by a low to high transition.</p>	R/C	0
7 (asyn)	TCD	<p>Termination Character Detected Interrupt (asyn./isochr.)</p> <p>This bit is set to '1', if a termination character is detected in the receive data stream. The SCC will insert a 'frame end / block end' indication to the SCC receive FIFO which causes the DMAC to finish the current receive descriptor.</p>	R/C	0
6 (asyn)	TIME	<p>Time Out Interrupt (asyn./isochr.)</p> <p>This bit is set to '1', if the time out limit is exceeded, i.e. no new character was received in a programmable period of time (refer to register CCR1 bit fields 'TOIE' and 'TOLEN' for more information).</p>	R/C	0

Bit	Symbol	Description	Access	Reset Value
5 (asyn)	PERR	<p>Parity Error Interrupt (asynch./isochr.)</p> <p>This bit is only valid if parity checking/generation is enabled via bit 'PARE' in register CCR2.</p> <p>It is set to '1', if a character with wrong parity has been received. If enabled via bit 'RFDF', this error status is additionally stored in the receive status byte generated for each receive character.</p>	R/C	0
4 (asyn)	FERR	<p>Frame Error Interrupt (asynch./isochr.)</p> <p>This bit is set to '1', if a character framing error is detected, i.e. a '0' was sampled at a position where a stop bit '1' was expected due to the selected character format.</p>	R/C	0
9:4 (hdlc)	-	Reserved (0 for reads)	R	0
3	PLLA	<p>DPLL Asynchronous Interrupt</p> <p>This bit is only valid, if the receive clock is derived from the internal DPLL and FM0, FM1 or Manchester data encoding is selected (depending on the selected clock source and data encoding mode). It is set to '1' if the DPLL has lost synchronization. Reception is disabled until synchronization has been regained again. If the transmitter is supplied with a clock derived from the DPLL, transmission is also interrupted.</p>	R/C	0
2	CDSC	<p>Carrier Detect Status Change Interrupt</p> <p>This bit is set to '1', if a state transition has been detected at signal CD. Because only a state transition is indicated via this interrupt, the current status can be evaluated by reading bit 'CD' in status register STAR.</p>	R/C	0
1	RFO	<p>Receive FIFO Overflow Interrupt</p> <p>This bit is set to '1', if receive data got lost because of a SCC receive FIFO full condition.</p>	R/C	0
0	-	Reserved (0 for reads)	R	0

Table 5-32: Interrupt Status Register

If CCR0.VIS is set to '1' then masked interrupt status bits will be visible in the ISR.

To clear these interrupt flags, the host CPU must write '1' to the corresponding ISR bit.

5.6.10 ACR – Additional Configuration Register (0x015C, 0x01DC, 0x025C, 0x02DC)

Bit	Symbol	Description	Access	Reset Value
31:2 2	-	Reserved (0 for reads)	R	0
21	STXFD	Reduced SCC TX FIFO Depth '0': max SCC TX FIFO Depth is 16 + 2 Byte '1': max SCC TX FIFO Depth is 2 + 2 Byte	R/W	0
20	SRTS	Special RTS Control Mode '0': RTS signal generation is controlled by CCR1.RTS and CCR1.FRTS bits (TX clock required) '1': RTS signal equals the CCR1.FRTS bit (no TX clock required) (for all modes) <i>Note: CCR1.FRTS bit is 0 by default. In special RTS control mode CCR1.FRTS should be set before the line interface is enabled.</i>	R/W	0
19	ETRBO	Extended Transparent mode Receive Bit Order '0': Receive Data is LSB first (first received bit at position 0) '1': MSB first (first received bit at position 7) <i>Note: Setting this bit to '1' might be useful to detect special characters more easily by software in the receive data stream. After detection of the byte alignment, the bits in each byte have to be mirrored to get the original data bytes.</i>	R/W	0
18	DTR3	Data Terminal Ready Channel 3 (Only on channel 3!)	R/W	0
17	CDOUT	CD Output Value	R/W	0
16	CDDIR	CD Direction '0': CD is input '1': CD is output	R/W	0
15	DCMRST	Reset the Clock Multiplier '0': Clock Multiplier is running '1': Clock Multiplier is held in Reset <i>Note: The Clock Multiplier should always be reset after changing its input clock</i>	R/W	0
14	X4MULT	Multiply BRG Input Clock x4 '0': No clock frequency change '1': BRG input clock frequency is multiplied by 4 <i>Note: The input frequency range of the x4 clock multiplier is 4.5 MHz to 28 MHz, these values must never be exceeded to ensure proper function of the clock multiplier.</i>	R/W	0

Bit	Symbol	Description	Access	Reset Value
13	RXCINV	Invert RxC '0': No inverting of RxC (the controller samples receive data bits with the falling RxC edge) '1': RxC is inverted (the controller samples receive data bits with the rising RxC edge)	R/W	0
12	TXCINV	Invert TxC '0': No inverting of TxC (the controller generates transmit data bits with the rising TxC edge) '1': TxC is inverted (the controller generates transmit data bits with the falling TxC edge)	R/W	0
11:1 0	RCS	Receiver Clock Source '00': BRG Output Clock '01': external RxC Input signal '10': DPLL Receive Clock '11': reserved	R/W	00
9:7	TCS	Transmitter Clock Source '000': BRG Output Clock '001': external RxC Input signal '010': external TxC (Input direction, CCR0.TOE=0!) '011': DPLL Transmit Clock '100': BRG Output Clock divided by 16 others: reserved	R/W	000
6:4	BCS	BRG Clock Source '000': Oscillator 1 Clock 14.7456 MHz '001': Oscillator 2 Clock 24 MHz '010': Oscillator 3 Clock 10 MHz '011': external RxC Input signal '100': external TxC (Input direction, CCR0.TOE=0) others: reserved	R/W	000
3	RTSCLK	Enable TxC Output on RTS pin '0': No TxC Output on RTS (normal function) '1': TxC Output Enabled on RTS	R/W	0
2:0	MODE	Transceiver Mode (M2:M0, see following table)	R/W	111

Table 5-33: Additional Configuration Register

The input frequency range of the x4 clock multiplier is 4.5 MHz to 28 MHz, these values must never be exceeded to ensure proper function of the clock multiplier.

Transceiver Mode	M2	M1	M0	Driver/Receiver Mode
Not Used (Default V.11)	0	0	0	TxD,TxC,RxD,RxC,RTS,CTS,CD: V.11
EIA-530A	0	0	1	TxD,TxC,RxD,RxC,RTS,CTS,CD: V.11
EIA-530	0	1	0	TxD,TxC,RxD,RxC,RTS,CTS,CD: V.11
X.21	0	1	1	TxD,TxC,RxD,RxC,RTS,CTS,CD: V.11
V.35	1	0	0	TxD,TxC,RxD,RxC: V.35 / RTS,CTS,CD: V.28
EIA-449/V.36	1	0	1	TxD,TxC,RxD,RxC,RTS,CTS,CD: V.11
V.28/EIA-232	1	1	0	TxD,TxC,RxD,RxC,RTS,CTS,CD: V.28
No Cable (high impedance)	1	1	1	TxD,TxC,RxD,RxC,RTS,CTS,CD: Z

Table 5-34: Physical Interface Mode Selection

6 Functional Description

Data transfers for each direction are handled via PCI DMA transfer.

The transfers are controlled via linked lists of descriptors stored in host memory. See the following chapter for a more detailed description of the descriptor and data structures.

The interrupt handling / operation concept is based on Interrupt Queues located in the system/shared memory.

There is a common on-chip interrupt vector FIFO and dedicated data FIFOs for each channel and direction.

The data is not swapped by the DMA Controller, it is always stored in little endian format.

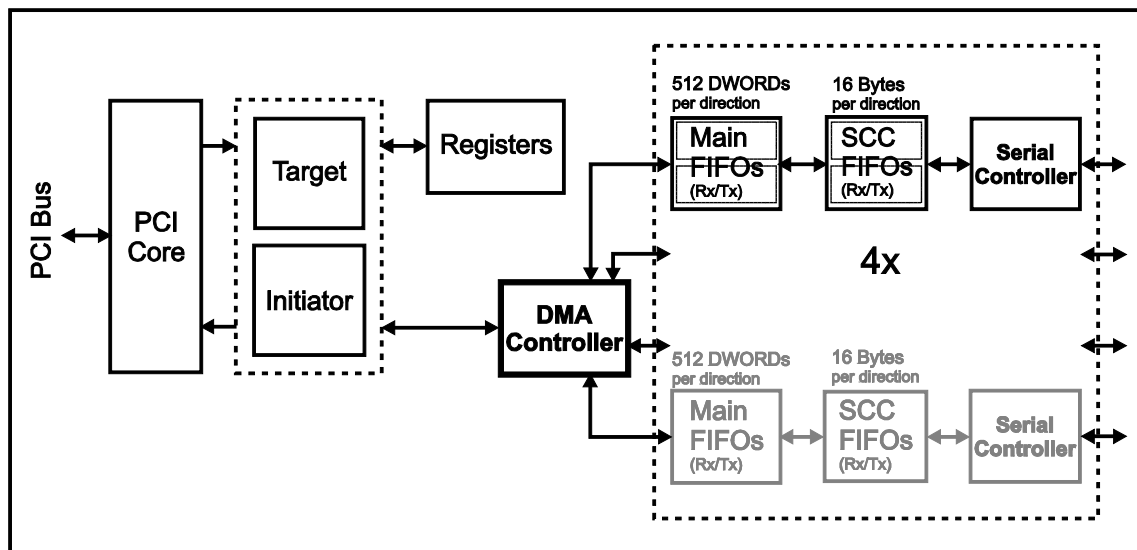

Figure 6-1 : FPGA On-Chip Block Diagram

6.1 DMA Controller

The CPU prepares linked lists for transmit and receive channels in the shared system memory. These may be handled by dynamically allocating and linking descriptors and buffers as required during runtime or by static predefined memory structures e.g. ring-chained-lists (the 'last' descriptor points back to the first descriptor). A mix of predefined descriptor lists but dynamically handled data buffers may also be an appropriate solution. This strategy depends on the specific application. The DMA Controller (DMAC) provides multiple control mechanisms supporting all of these combinations in an efficient way.

The descriptors and data buffers can be stored in separate memory spaces within the 32-bit address range allowing full scatter/gather methods of assembling and disassembling of packets.

Each descriptor contains a 'next descriptor address' field to implement the linked list. Because the DMA controller cannot distinguish between valid and invalid addresses, a 'Hold' mechanism is implemented to prevent the DMA controller from branching to invalid memory locations.

Two alternative control mechanisms are provided to detect and handle descriptor list end conditions:

- Hold bit control mode (the user marks a certain descriptor with a hold flag)
- Last descriptor address control mode (the user defines a certain descriptor address as a hold condition)

The Control Mode applies to all DMA channels transmit and receive and is selected via bit 'CMODE' in Global Mode Register GMODE.

An HDLC frame may fit in one buffer connected to one descriptor or it may be split to several buffers each associated with linked descriptors. A 'frame end' indication (FE bit) will be set in each descriptor which points to the last buffer of a HDLC frame.

The 'frame end' indications are stored in the internal FIFOs and affect the FIFO control mechanisms. Therefore descriptor 'frame end' indications (FE bit) are also used in non frame oriented protocol modes such as ASYNC mode. They are referred to as 'frame end/block end' indication in the following chapters.

6.1.1 DMAC Transmit Descriptor Lists

Each transmit descriptor consists of 4 consecutive DWORDs located DWORD aligned in the shared memory. The first 3 DWORDs are written by the host and read by the corresponding DMA channel using a burst transaction, when requested by the host either via an 'AR' (Action Request) command or a transmit poll command or after branching from previous transmit descriptors in the linked list. The transmit descriptor provides information about the next descriptor in the linked list, the attached transmit data buffer address and size, as well as some control bits.

The fourth DWORD is written by the DMA channel indicating that operation on this descriptor is finished.

The CPU will write the address of the first descriptor of each linked list to a dedicated Base Address Register (BTDAi) during the channel initialization procedure. The corresponding DMA channel starts processing the descriptor list by fetching the first descriptor from this address.

6.1.1.1 Transmit Descriptor

DWORD	31	30	29	28..16	15..0
0	FE	HOLD	HI	NO	0
1	Next Transmit Descriptor Pointer				
2	Transmit Data Pointer				
3	0	C	0		

Table 6-1 : Transmit Descriptor

FE: Frame End Bit

Indicates that the current transmit data section (addressed by Transmit Data Pointer) contains the end of a frame (HDLC) or the end of data block (ASYNC). When transferring the last data from this transmit data section into the internal FIFO the DMAC marks this data with a 'frame end / block end' indication bit.

GMODE.CMOD = '0' (Hold Mode):

After completing a descriptor the DMAC checks the HOLD bit (previously read with the transmit descriptor). If HOLD = 0, it branches to the next transmit descriptor. Otherwise the corresponding DMAC transmit channel is deactivated as long as the host CPU does not request reactivation via the GCMR register (either transmit poll request or action request with 'IDT' command).

GMODE.CMOD = '1' (Last Address Mode):

After completing a descriptor the DMAC checks if the first (current) transmit descriptor address (FTDA) is equal to the last transmit descriptor address (LTDA) stored in the corresponding channel specific on-chip registers. When both addresses differ, it branches to the next transmit descriptor. Otherwise the corresponding DMAC transmit channel is deactivated as long as the host CPU does not write a new address to the LTDA register or provides an action request with the 'IDT' command.

HOLD: Hold Bit

Only valid if GMODE.CMODE = '0' (Hold Mode).

Used for descriptor list end control.

HOLD = '0':

A next descriptor is available in the shared memory. After checking the HOLD bit the DMAC branches to the next transmit descriptor.

HOLD = '1':

The current descriptor is the last one (currently) available for the DMAC. The corresponding DMAC channel is deactivated for transmit direction as long as the microprocessor does not request an activation via the CMDR register.

NO: Byte Number

NO defines the number of bytes (stored in the data section) to be transmitted. Thus the maximum length of the data buffer is 8191 bytes (NO = 0x1FFF). A transmit descriptor and the corresponding data section must contain at least either one data byte or a frame end indication. Otherwise a DMA controller interrupt with 'ERR' bit set is generated.

HI: Host Initiated Interrupt

If the HI bit is set, the corresponding DMAC generates an HI interrupt after transferring all data bytes of the current transmit data section.

Next Transmit Descriptor Pointer:

This 32-bit pointer contains the start address of the next transmit descriptor. After fetching the indicated number of data bytes, the DMAC branches to the next transmit descriptor. The transmit descriptor is read entirely at the beginning of the transmit descriptor processing and is stored in on-chip memory. Therefore when the DMAC branches to a (next) descriptor all descriptor information must be valid. This pointer is not used if a transmitter reset or initialization channel command is detected while the DMAC still reads data from the current transmit descriptor. In this case the value in the BTDA register is used as a pointer for the next transmit descriptor.

The descriptor start address must be DWORD aligned.

Transmit Data Pointer:

This 32-bit pointer contains the start address of the transmit data section for a transmit descriptor. Although the TAMC863 works long word oriented, it is possible to begin transmit data section at byte addresses.

C: Complete Bit

This bit is set by the DMAC if

- it completes reading a data section normally
- it was aborted by a transmitter reset command.

6.1.2 DMAC Receive Descriptor Lists

Each receive descriptor consists of 5 consecutive DWORDs located DWORD aligned in the shared memory. The first 3 DWORDs are read by the corresponding DMA channel using a burst transaction and provide information about the next descriptor in the linked list, the attached receive data buffer address and size, as well as some control bits.

The fourth DWORD is written by the DMA channel indicating that operation on this descriptor is finished. The fifth DWORD is also written by the DMA channel but only for descriptors containing the first or only data section of an HDLC frame or data block. It is a pointer to the last descriptor containing the frame or block end ('FE' bit) allowing the software to unchain the complete partial descriptor list containing a frame or block without parsing through the list for 'FE' indication.

The CPU will write the address of the first descriptor of each linked list to a dedicated Base Address Register during the initialization procedure. The corresponding DMA channel starts operating the linked lists at this address.

6.1.2.1 Receive Descriptor

DWORD	31	30	29	28..16	15..8	7..0
0	0	HOLD	HI	NO	0	
1	Next Receive Descriptor Pointer					
2	Receive Data Pointer					
3	FE	C	0	BNO	STATUS	0
4	Frame End Descriptor Pointer					

Table 6-2 : Receive Descriptor

HOLD: Hold Bit

Only valid when GMODE.CMODE = '0' (Hold Mode)

Used for descriptor list end control.

HOLD = '0':

A next descriptor is available in the shared memory. After checking the HOLD bit the DMAC branches to next receive descriptor

HOLD = '1':

The current descriptor is the last one (currently) available for the DMAC. After completion of the current receive descriptor an interrupt is generated and the corresponding DMAC channel is deactivated for receive direction as long as the host CPU does not request an activation via the CMDR register.

HI: Host Initiated Interrupt

If the HI bit is set, the corresponding DMAC generates an HI interrupt after transferring all data bytes into the current data section.

NO: Byte Number

NO defines the size of the receive data buffer allocated by the host. It has to be a multiple of 4 bytes which is the responsibility of the software. The maximum buffer length is 8188 bytes (i.e. NO = 0x1FFC).

Note that the receive data buffer may be needed to reserve space for up to two additional 32-bit words (HDLC 32 bit CRC plus status word or Async Frame/Block-End word).

Next Receive Descriptor Pointer:

This 32-bit pointer contains the start address of the next receive descriptor. After completing the current receive descriptor the DMAC branches to the next receive descriptor to continue reception. The receive descriptor is read entirely at the beginning of the descriptor processing and stored in on-chip memory. Therefore when the DMAC branches to a (next) descriptor all descriptor information must be valid.

Descriptor start address must be DWORD aligned.

Receive Data Pointer:

This 32-bit pointer contains the start address of the receive data section for a receive descriptor. The start address must be DWORD aligned.

FE: Frame End Bit

Indicates that the current receive data section contains the end of a frame (HDLC) or the end of a data block (ASYNC). This bit is set by the DMAC after transferring the last data from the internal receive FIFO into the receive data section. Moreover the BNO and STATUS fields are updated and the 'C' bit is set by the DMAC.

GMODE.CMODE = '0' (Hold Mode):

After completing a descriptor the DMAC checks the HOLD bit (previously read with the receive descriptor). If HOLD = 0, it branches to the next receive descriptor. Otherwise the corresponding DMAC receive channel is deactivated as long as the host CPU does not request reactivation via the GCMR register (action request with 'IDR' command).

GMODE.CMODE = '1' (Last Address Mode):

After completing a descriptor the DMAC checks if the first (current) receive descriptor address (FRDA) is equal to the last receive descriptor address (LRDA) stored in the corresponding channel specific on-chip registers. When both addresses differ, it branches to the next receive descriptor. Otherwise the corresponding DMAC receive channel is deactivated as long as the host CPU does not write a new value to the LRDA register or provides an action request with 'IDR' command.

C: Complete Bit

This bit is set by the DMAC if:

- it completed filling the receive data section normally
- it was aborted by a receiver reset command
- an end of frame (HDLC) or end of block (ASYNC) has been stored in the receive data section.

BNO: Byte Number of Received Data

The DMAC writes the actual number of data bytes that were stored in the current receive data section into the BNO field (including CRC and status bytes).

Receive descriptor STATUS

7	6	5	4	3	2	1	0
0	0	0	0	0	0	RA	0

Table 6-3 : Receive Descriptor Status Field

RA: Receive Abort

This bit indicates that the reception of a frame (HDLC) or block (ASYNC) was ended by a DMA receiver reset command or by a HOLD bit in the current receive descriptor or by a FRDA = LRDA condition.

Frame End Descriptor Pointer:

This 32-bit pointer is only valid in the descriptor, which contains the data pointer to the first data section of an HDLC frame or ASYNC block. This pointer is written by the DMAC with the address of the descriptor that contains the data pointer to the last data section (FE) of the HDLC frame or ASYNC block.

6.1.2.2 Receive Data Section Status Byte (HDLC Mode)

In HDLC protocol mode, the last byte of a frame (Receive Status Byte, RSTA) written to the receive data section contains error indications caused by the SCC (e.g. CRC, receive abort, ...).

7	6	5	4	3	2	1	0
1	RFO	CRC	RAB	0	0	0	0

Table 6-4 : Receive Data Section Status Byte (HDLC)

The contents of the RSTA byte relate to the received HDLC frame and are generated when end-of-frame is recognized at the serial receive interface.

RFO: Receive FIFO Overflow

A data overflow has occurred during reception of the frame. Additionally, an interrupt can be generated (refer to ISR.RFO / IMR.RFO).

CRC: CRC Compare/Check

'0': CRC check failed, received frame contains errors.

'1': CRC check OK, no errors detected in received frame.

RAB: Receive Message Aborted

The received frame was aborted from the transmitting station. According to the HDLC protocol, this frame must be discarded by the receiver station.

6.1.2.3 Receive Data Section Status Byte (ASYNC Modes)

In ASYNC protocol mode a status byte can be attached additionally to every stored data byte (CCR2.RFDF = '1').

The data character and status character format is determined as follows:

15	14	13..9	8	7..0
parity error	frame error	reserved	parity bit	data byte

Table 6-5 : Receive Data Section Status Byte (ASYNC)

6.2 DMAC Interrupt Controller

The interrupt concept is based on 32-bit interrupt vectors generated by the different blocks. Interrupt vectors are stored in a common on-chip interrupt FIFO which is 32 DWORDs deep. The interrupt controller transfers interrupt vectors to one of nine circular interrupt queues located in the shared system memory depending on the source ID of each interrupt vector.

In addition new interrupt vectors are indicated in the global status register GSTAR on a per queue basis and selectively confirmed by writing '1' to the corresponding GSTAR bit positions. The PCI interrupt signal INTA is asserted with any new interrupt event and remains asserted until all events have been confirmed.

Each interrupt queue length and memory location can be configured via specific interrupt queue base address registers and two shared interrupt queue length registers. The queue length is individually programmable in multiples of 32 DWORDs (see IQLENR0/1 registers).

One dedicated interrupt queue is provided per SCC channel and direction (IQSCCiRX and IQSCCiTX). Non channel specific interrupt vectors generated by the DMAC are transferred to the configuration queue IQCFG.

The internal blocks provide mask registers for suppressing interrupt indications. Masked interrupts will neither generate an interrupt vector nor an INTA signal or GSTAR indication.

6.2.1 DMA Controller initiated Interrupts

The DMA interrupt controller generates channel/direction specific interrupts regarding transmit and receive descriptor handling:

Host Initiated interrupt (HI):

This interrupt can be forced by setting bit 'HI' in the receive or transmit descriptor. In this case the DMAC will generate an HI-interrupt with completion of this descriptor i.e. when the DMAC is ready to branch to the next descriptor address. This might be used to monitor the progress of the corresponding DMA channel on the descriptor list. As an example the HI interrupt can be used to dynamically request attachment of new receive descriptors to the list if the DMA channel comes close to the list end.

Frame Indication interrupt (FI):

This interrupt is generated with completion of any receive or transmit descriptor with a set 'frame end/block end' indication, i.e. FE='1'.

Error interrupt (ERR):

Indicates an unexpected descriptor configuration

Receive descriptor:

ERR is generated if receive data cannot be transferred to the shared memory completely because the frame (block) does not fit into the current data section and a HOLD condition (HOLD bit or LRDA=FRDA) prevents the DMAC from branching to the next descriptor.

ERR is also generated if an already started DMA transfer is aborted by a receive DMA reset (RDR) command.

Transmit descriptor:

In transmit direction an ERR interrupt is generated if one of the following descriptor settings is detected

- HOLD='1' and FE='0' (the already started transmit frame could not be finished)
- LTDA=FTDA and FE='0' (the already started transmit frame could not be finished)
- FE='0' and NO='0' (a packet of length 0 is supposed to be a 'frame' with FE bit set)

The DMA controller will continue 'normal' operation in case of an ERR event. Nevertheless these cases may result in receive data overflows or transmit data underruns.

FI and HI interrupt indications caused by one descriptor will be generated into one interrupt vector with 'HI' and 'FI' bit set.

6.2.2 Interrupt Vector Description

6.2.2.1 Configuration Interrupt Vector

Configuration interrupt vectors are transferred to the Configuration Interrupt Queue 'IQCFG' in the shared memory.

31..28	27..2	1	0
Source ID = 1010	0	ARF	ARACK

Table 6-6 : Configuration Interrupt Vector

ARF: Action Request Failed Interrupt

This bit indicates that an action request command was completed with an 'action request failed' condition:

ARF = '0': No action request was performed or no 'action request failed' condition occurred completing an action request.

ARF = '1': The last action request command was completed with an 'action request failed' condition.

ARACK: Action Request Acknowledge Interrupt

This bit indicates that an action request command was completed successfully:

ARACK = '0': No action request was performed or completed successfully.

ARACK = '1': The last action request command was completed successfully.

6.2.2.2 DMA Controller Interrupt Vector

DMA controller interrupt vectors are transferred to the corresponding channel and direction specific interrupt queues IQSCCiRX and IQSCCiTX respectively.

31	30..28	27..19	18	17	16	15..0
0	Source ID	0	HI	FI	ERR	0

Table 6-7 : DMA Interrupt Vector

Source-ID	Description
000	Receive Channel 0 Interrupt Vector (IQSCC0RX)
001	Receive Channel 1 Interrupt Vector (IQSCC1RX)
010	Receive Channel 2 Interrupt Vector (IQSCC2RX)
011	Receive Channel 3 Interrupt Vector (IQSCC3RX)
100	Transmit Channel 0 Interrupt Vector (IQSCC0TX)
101	Transmit Channel 1 Interrupt Vector (IQSCC1TX)
110	Transmit Channel 2 Interrupt Vector (IQSCC2TX)
111	Transmit Channel 3 Interrupt Vector (IQSCC3TX)

Table 6-8 : DMA Interrupt Vector Source-IDs

HI: Host Initiated interrupt (Rx/Tx Channel)

This bit indicates that a Host Initiated (HI) interrupt occurred, i.e. the corresponding DMA controller channel detects the 'HI' bit set to '1' in the receive or transmit descriptor before branching to the next descriptor.

HI='0' No Host Initiated (HI) interrupt is indicated by this vector.

HI='1' A Host Initiated (HI) interrupt is indicated by this vector.

FI: Frame Indication interrupt (Rx/Tx Channel)

This bit indicates that a Frame Indication (FI) interrupt occurred.

Receive direction:

FI='1' indicates, that a frame has been received completely or was stopped by a DMAC receiver reset command or a hold condition set in a receive descriptor. It is set when the DMAC branches from the last descriptor belonging to the current frame (or block) (FE='1') to the first descriptor of a new frame. It is also set when the descriptor in which the frame/block is finished contains a hold condition.

Transmit direction:

Issued if the 'FE' bit is detected in the transmit descriptor. It is set when the DMAC branches to the next transmit descriptor, belonging to a new frame or when 'HOLD' bit is set in conjunction with 'FE' bit. 'ERR' indication (without 'FI') is set, if a transmit descriptor contains a 'HOLD' (hold condition) but no 'FE' bit.

FI='0' No Frame Indication (FI) interrupt is indicated by this vector.

FI='1' A Frame Indication (FI) interrupt is indicated by this vector.

ERR: ERROR Indication interrupt (Rx/Tx Channel)

This bit indicates that an Error interrupt occurred.

Receive direction:

Issued if the current frame/block could not be transferred to the shared memory completely, because of a hold condition in a receive descriptor not providing enough bytes for the frame/block or the frame/block was aborted by a DMAC receiver reset command.

Transmit direction:

Issued if a transmit descriptor contains a hold condition but FE='0' or if the last descriptor had NO=0 and FE='0'.

ERR='0' No Error (ERR) interrupt is indicated by this vector.

ERR='1' An Error (ERR) interrupt is indicated by this vector.

6.2.2.3 SCC Interrupt Vector

Serial Channel (SCC) related interrupt vectors are transferred to the corresponding channel and direction specific interrupt queues IQSCCiRX and IQSCCiTX respectively.

Interrupt vectors generated by the SCCs might contain interrupt indications for both, receive AND transmit direction. But in receive interrupt queues only the receive interrupt indications need to be served and in transmit interrupt queues only transmit interrupt indications need to be served by the software.

31	30..28	27..24	23..19	18	17	16
0	Source ID	0010	0	ALLS	0	XDU

15	14	13..10	9	8	7	6	5	4	3	2	1	0
0	CSC	0	BRK	BRKT	TCD	TIME	PERR	FERR	PLLA	CDSC	RFO	0

Table 6-9 : SCC Interrupt Vector

Source-ID	Description
000	Receive Channel 0 Interrupt Vector (IQSCC0RX)
001	Receive Channel 1 Interrupt Vector (IQSCC1RX)
010	Receive Channel 2 Interrupt Vector (IQSCC2RX)
011	Receive Channel 3 Interrupt Vector (IQSCC3RX)
100	Transmit Channel 0 Interrupt Vector (IQSCC0TX)
101	Transmit Channel 1 Interrupt Vector (IQSCC1TX)
110	Transmit Channel 2 Interrupt Vector (IQSCC2TX)
111	Transmit Channel 3 Interrupt Vector (IQSCC3TX)

Table 6-10: SCC Interrupt Vector Source-IDs

Bit field [18:0] of the SCC interrupt vector is a copy of the SCC Interrupt Status Register ISR (for detailed information see chapter 'ISR - Interrupt Status Register').

7 Serial Communication Controller

7.1 Protocol Description

The following table provides an overview of all supported protocol modes and their assignment to the major protocol engines HDLC and ASYNC. The protocol engine of each SCC is selected via bit field 'SM' in register CCR0. The Sub Modes are selected via additional bit fields in registers CCR0 and CCR1.

Protocol Engine	CCR0 Register Setting	Protocol Mode	CCR1 Register Setting
HDLC	SM = '00'	HDLC Address Mode 0	MDS = '10'
		Extended Transparent Mode	MDS = '11'
ASYNC	SM = '11'	Asynchronous Mode	BCR = '1'
		Isochronous Mode	BCR = '0'

Table 7-1 : Protocol Modes

Extended transparent is a fully bit-transparent transmit/reception mode which is treated as a sub-mode of the HDLC block.

7.1.1 HDLC Mode

The HDLC transmitter does not generate shared flags or shared zeroes between flags. The HDLC receiver supports shared flags and shared zeroes between flags.

7.1.1.1 Address Mode 0

Standard HDLC framing and bit-stuffing is performed by the transmitter. There is an option to append 16 bit or 32 bit CRC data for each frame.

The receiver will store the frame data (including CRC) plus a status byte.

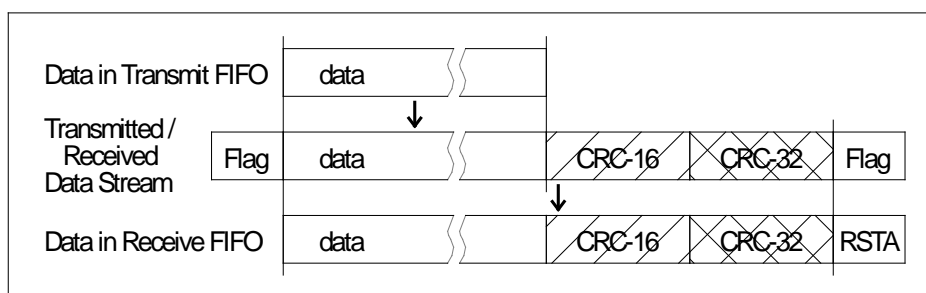

Figure 7-1 : HDLC Address Mode 0

7.1.1.2 Extended Transparent Mode

In extended transparent mode, fully transparent data transmission/reception without HDLC framing is performed (i.e. without FLAG generation/recognition, CRC generation/check, or bit stuffing). This allows user specific protocol variations.

7.1.2 Asynchronous (ASYNC) Mode

Character framing is achieved by start and stop bits. Each data character is preceded by one start bit and terminated by one or two stop bits. The character length is selectable from 5 to 8 bits. Optionally, a parity bit can be added which complements the number of ones to an even or odd quantity (even/odd parity). The parity bit can also be programmed to have a fix value (Mark or Space). The character format configuration is performed via appropriate bit fields in register CCR2.

7.1.2.1 Asynchronous Mode

NRZ data encoding and Bit clock rate x16 (register CCR0, bit BCR = '1') shall be selected (register CCR0, bit field 'SC').

The transmitter operates at a clock rate which is 16 times the nominal data bit rate. The generated data bit rate is 1/16 of the transmit clock rate.

The receiver operates at a clock rate which is 16 times the nominal (expected) data bit rate. It synchronizes itself to each character by detecting and verifying the start bit. Oversampling (3 samples) around the nominal bit center in conjunction with majority decision is provided for every received bit (including start bit).

The synchronization lasts for one character; the next incoming character causes a new synchronization. As a result, the demand for high clock accuracy is reduced. Two communication stations using the asynchronous procedure are clocked independently; their clocks need not to be in phase or locked to exactly the same frequency but, in fact, may differ from one another within a certain range.

7.1.2.2 Isochronous Mode

Bit clock rate x1 shall be selected (register CCR0 bit BCR = '0').

The isochronous mode uses the asynchronous character format. However, each data bit is only sampled once (no oversampling). The input clock has to be externally phase locked to the data stream. This mode allows much higher transfer rates.

7.1.2.3 Receive Data Storage

If the receiver is enabled, received data is stored in the receive FIFO (the LSB is received first). Character length, number of stop bits and the optional parity bit are checked. Errors are indicated via interrupts. Additionally, the character specific error status (framing and parity) can optionally be stored in the receive FIFO. Filling of the receive FIFO is controlled by

- a programmable threshold level (bit field 'RFTH' in register CCR2),
- the selected data format (bit 'RFDF' in register CCR2),
- detection of the programmable Termination Character (bit 'TCDE' and bit field 'TC' in register TCR).

Additionally, the time-out event interrupt as an optional status information indicates that a certain time has elapsed since the reception of the last character (refer to register CCR1).

7.1.2.4 Data Transmission

The selection of asynchronous or isochronous operation has no further effect on the transmitter. The bit clock rate is solely a dividing factor for the selected clock source.

Transmission of the contents of the transmit FIFO starts after providing data to the DMA controller. The character frame for each character, consisting of start bit, the character itself with defined character length, optionally generated parity bit and stop bit(s) is assembled.

After finishing transmission (indicated by the 'ALLS' interrupt), IDLE sequence (logical '1') is transmitted on transmit pin TxD.

Additionally, the CTS signal may be used to control data transmission.

7.1.2.5 Break Detection/Generation

Break generation:

On generating the transmit break command (bit 'XBRK' in register CCR2), the TxD pin is immediately forced to physical '0' level with the next following clock edge, and released with the first clock edge after this command is reset again by software.

Break detection:

The SCC recognizes the break condition upon receiving consecutive (physical) '0's for the defined character length, the optional parity and the selected number of stop bits ('zero' character and framing error). The 'zero' character is not pushed to the receive FIFO. The 'Break' interrupt (BRK) is generated (if enabled). The break condition will be present until a '1' is received which is indicated by the 'Break Terminated' interrupt (BRKT).

7.1.2.6 Flow Control

Transmitter:

The transmitter output is enabled if CTS signal is 'LOW'. Setting bit CCR1.FCTS = '1' allows the transmitter to send data independent of the condition of the CTS signal.

Receiver:

For some applications it is desirable to provide means of flow control to indicate to the far end transmitter that the local receiver's buffer is getting full.

This flow control can be used between two DTEs and between a DTE and a DCE (MODEM) that supports this kind of bi-directional flow control.

Setting bit CCR1.FRTS = '1' and CCR1.RTS = '0' invokes the receiver flow control. When the SCC receive FIFO data-count reaches the upper threshold of 12 bytes (16 bytes total), the RTS signal is forced inactive (HIGH). When the receive FIFO data-count is less or equal to the lower threshold of 4 bytes, the RTS signal is re-asserted ('LOW'). Note that data is immediately transferred from the SCC receive FIFO to the DMA accessible FIFO (as long as there is space available). Thus when the SCC receive FIFO reaches the upper threshold, there are 4 more bytes storage available before an overflow may occur. This provides sufficient time for the far end transmitter to react to the change in the RTS signal and stop sending more data.

7.2 Clock Sources

The TAMC863 supports several clock sources for the transmitter and receiver circuits, controlled by the ACR register. Clock source options are three on board oscillators (14.7456 MHz, 24 MHz and 10 MHz), the external RxCLK and TxCLK inputs or the internal clock recovery circuit (DPLL). TxCLK can be an input for the internal transmit clock or an output providing a transmit clock monitor signal (see following figure).

The guaranteed maximum data rate is limited by the multiprotocol transceivers and is at least 10 Mbit/s in EIA-530 (V.11) and V.35 transceiver modes. Maximum data rate of EIA-232 (V.28) is 115.2 kbit/s. The maximum data rate in asynchronous mode with oversampling or synchronous DPLL mode is 2 Mbit/s. To generate higher internal clock frequencies for oversampling or DPLL reference clock, an optional x4 clock multiplier is provided.

The input frequency range of the internal x4 clock multiplier is 4.5 MHz to 28 MHz, these values must never be exceeded to ensure proper function of the clock multiplier.

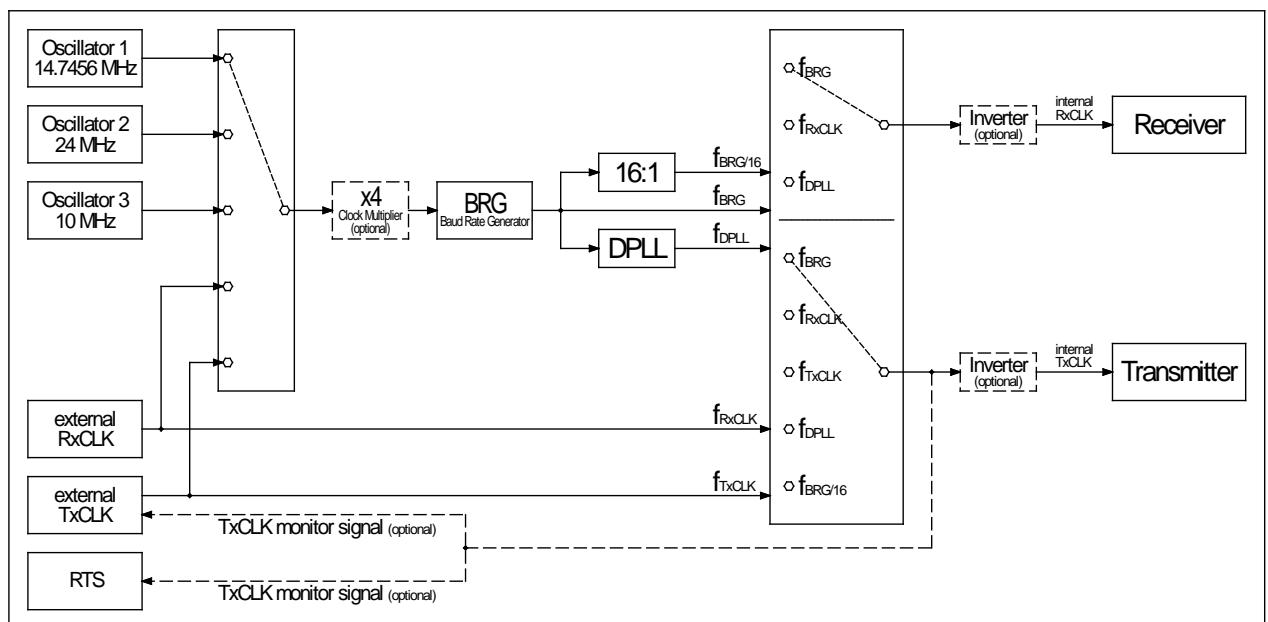

Figure 7-2 : Clock Sources

7.3 Baud Rate Generation

Each of the four channels has its own Baud Rate Generator (BRG), controlled by the BRR registers (0x012C, 0x01AC, 0x022C, 0x02AC).

The Baud Rate Generator output clock frequency is: $f_{BRG} = f_{in} / k$.

The baud rate generator input clock f_{in} depends on the selected clock source (see also previous chapter "Clock Sources").

The divisor k can be set in 2 ways, determined by BRR[31].

When BRR[31] = 0, k is calculated as follows:

$$k = (N + 1) \times 2^M$$

with N (BRR[5:0]) = 0..63 and M (BRR[11:8]) = 0..15

The alternative is to set $(k - 1)$ directly as a 21-bit wide value, when BRR[31] = 1:

$$k = \text{BRR}[20:0] + 1$$

7.4 Data Encoding

The following codings of the serial data are supported:

- Non-Return-To-Zero (NRZ)
- Non-Return-To-Zero-Inverted (NRZI)
- FM0 (known as Bi-Phase Space)
- FM1 (known as Bi-Phase Mark)
- Manchester (known as Bi-Phase)

NRZ data encoding must be used for asynchronous mode.

7.4.1 NRZ and NRZI Encoding

NRZ: The signal level corresponds to the value of the data bit.

NRZI: A logical '0' is indicated by a transition and a logical '1' by no transition at the beginning of the bit cell.

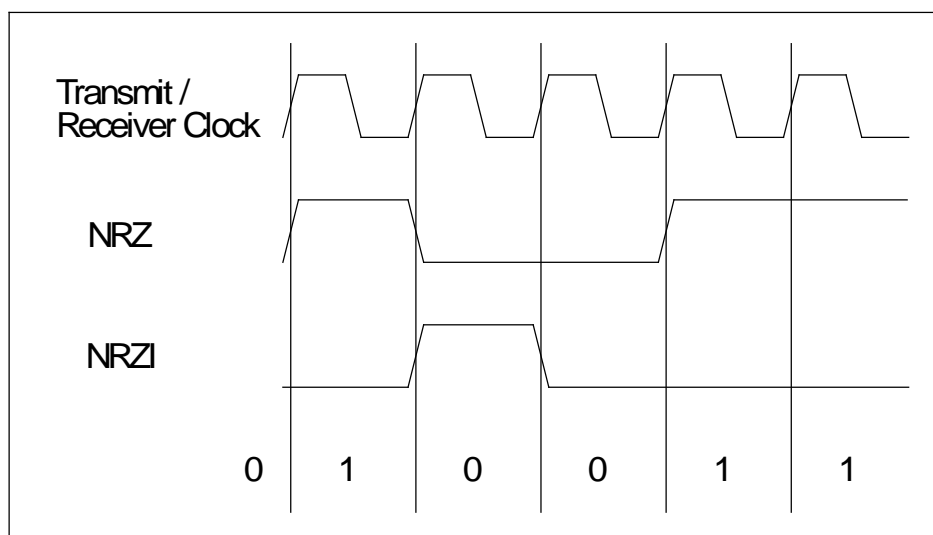

Figure 7-3 : NRZ and NRZI Data Encoding

7.4.2 FM0 and FM1 Encoding

FM0: An edge occurs at the beginning of every bit cell. A logical '0' has an additional edge in the center of the bit cell, whereas a logical '1' has none. The transmit clock precedes the receive clock by 90°.

FM1: An edge occurs at the beginning of every bit cell. A logical '1' has an additional edge in the center of the bit cell, whereas a logical '0' has none. The transmit clock precedes the receive clock by 90°.

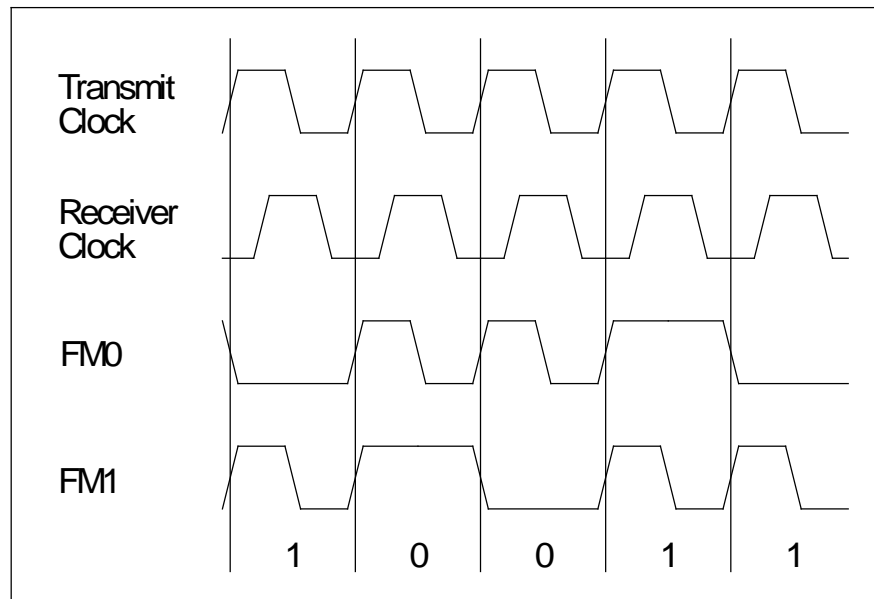

Figure 7-4 : FM0 and FM1 Data Encoding

7.4.3 Manchester Encoding

In the first half of the bit cell, the physical signal level corresponds to the logical value of the data bit. At the center of the bit cell this level is inverted. The transmit clock precedes the receive clock by 90°.

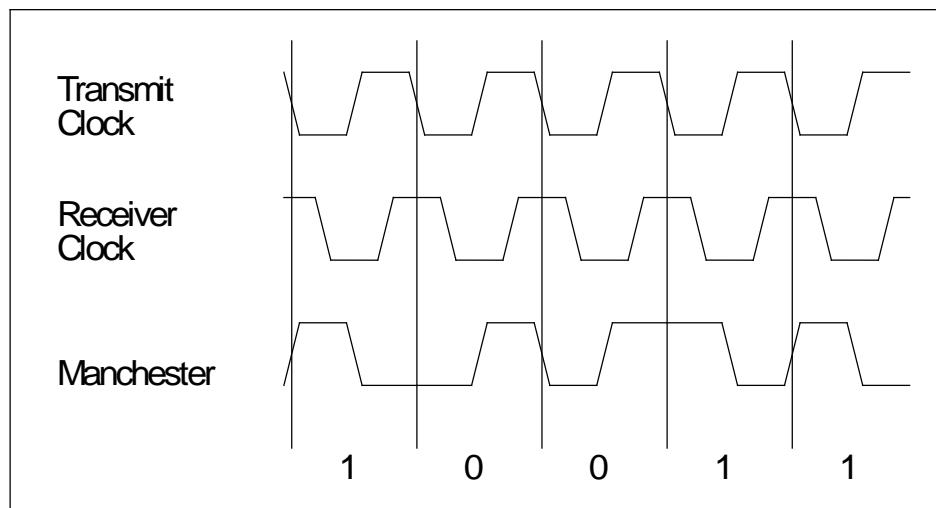

Figure 7-5 : Manchester Data Encoding

7.5 Clock Recovery (DPLL)

FM0, FM1 and Manchester data encodings are eliminating the need to transfer additional clock information via a separate serial clock line (so there is no additional clock signal transferred along with the data stream). Instead the clock signal is recovered from the receive data stream by the use of the internal DPLL circuit.

The main task of the DPLL (digital-phase-locked-loop) is to derive the receive clock from the incoming data stream and to adjust its phase to the incoming data in order to provide optimal bit sampling.

The DPLL reference clock is the baud rate generator output clock which must be set to be 16 times the expected data rate. The receive clock source must be set to 'DPLL' (ACR.RCS = '10'). The transmit clock source may set to be the baud rate generator output clock divided by 16 (ACR.TCS = '100') or to be the transmit clock generated by the DPLL circuit (ACR.TCS = '011').

The mechanism for the DPLL clock recovery depends on the selected data encoding (see chapter "Data Encoding").

8 Configuration Hints

8.1 Big / Little Endian

PCI – Bus (Little Endian):

Byte 0	AD[7..0]
Byte 1	AD[15..8]
Byte 2	AD[23..16]
Byte 3	AD[31..24]

The TAMC863 expects all accesses by the host/CPU and all data structures in the host/system RAM to be 'Little Endian'.

Transmit data in lower bytes is sent first.

Receive data that was received earlier is stored at lower bytes.

8.2 Configuration EEPROM

An industry standard M93C56 2 Kbit serial EEPROM is connected to the FPGA and can be accessed through the GCTLR register. The EEPROM is configured for word (16 bit) accesses.

Addresses 0x00...0x5F are factory programmed with configuration information used by the software drivers and **must not be overwritten**.

The other addresses (0x60...0x7F) are user programmable.

The configuration EEPROM contains the following data:

- Vendor ID
- Vendor Device ID
- Subsystem Vendor ID
- Subsystem Device ID
- The module version and revision
- The oscillator frequencies in Hz
- The physical interface attached to the serial channels
- The maximal baud rate of the transceivers in bps
- The supported control signals of the serial channels

For the physical interfaces and the control signals applies: Bit 3 represents UART channel 3 and bit 0 represents UART channel 0. The appropriate bit is set to '1' for each UART channel attached to the physical interface represented by the word. Bit 15 to bit 4 are always '0'.

Address	Configuration Register	TAMC863
0x00	Vendor ID	0x1498
0x01	Device ID	0x835F
0x02	Subsystem Vendor ID	0x1498
0x03	Subsystem ID	0x800A
0x04	Module Version	0x0100
0x05	Module Revision	0x0000
0x06	Module Variant	0x800A
0x07	EEPROM Revision	0x0001
0x08	Oscillator 1 Frequency (high)	0x00E1
0x09	Oscillator 1 Frequency (low)	0x0000
0x0A	Oscillator 2 Frequency (high)	0x016E
0x0B	Oscillator 2 Frequency (low)	0x3600
0x0C	Oscillator 3 Frequency (high)	0x0098
0x0D	Oscillator 3 Frequency (low)	0x9680
0x0E-0x0F	Reserved	-
0x10	RS232 Channels	0x000F
0x11	RS422 Channels	0x000F
0x12-0x14	Reserved	-
0x15	Multiprotocol Channels	0x000F
0x16-0x1E	Reserved	-
0x1F	Programmable Interfaces	0x000F
0x20	Max Data Rate RS232 (high)	0x0001
0x21	Max Data Rate RS232 (low)	0xF400
0x22	Max Data Rate RS422 (high)	0x0098
0x23	Max Data Rate RS422 (low)	0x9680
0x24-0x2F	Reserved	-
0x30	RxD & TxD	0x000F
0x31	RTS & CTS & CD	0x000F
0x32	Full modem	0x0008
0x33-0x5F	Reserved	-
0x60-0x7F	User programmable space	-

Table 8-1 : Configuration EEPROM Data

8.3 Additional Termination Resistors

The Rx-/Tx-Clock and Data I/O lines are connected to LTC1546 transceivers with on-chip termination.

The control I/O lines (RTS, CTS, CD) are connected to LTC1544 transceivers without on-chip termination, as termination of these signals is not necessary in the normal case. If the application requires on board termination for these lines please contact TEWS Technologies.

8.4 Transmit & Receive Clock Polarity

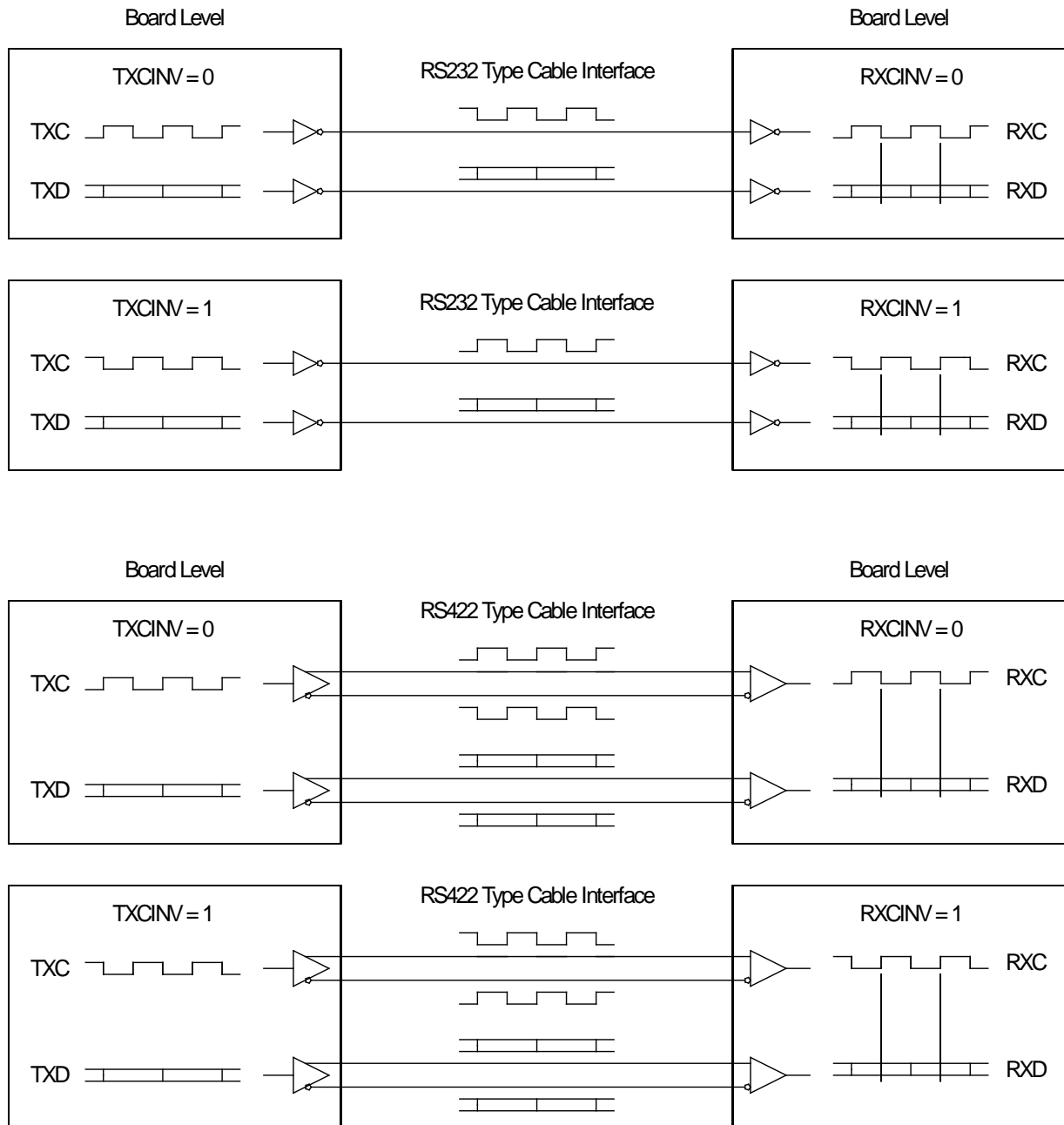

Figure 8-1 : Transmit & Receive Clock Polarity

9 Module Management

9.1 Indicators

For a quick visual inspection the TAMC863 provides LEDs at the front panel and also an on board LED.

9.1.1 Front Panel LEDs (MMC controlled)

LED	Color	State	Description
HS	Blue	Off	No Power or module is powered
		Short Blink	Hot-Swap negotiation (extraction)
		Long Blink	Hot-Swap negotiation (insertion)
		On	Module is ready to attempt activation (insertion) or Module is ready to be extracted (extraction)
FAIL	Red	Off	No Failure
		On	Failure or out of service status
ACT	Green	Off	Board is not powered up
		On	Board is powered and status OK
		On (Off Flash)	PCI DMA activity

Table 9-1 : Front Panel LEDs (MMC controlled)

9.1.2 On Board LEDs

LED	Color	State	Description
Link Down	Red	Off	PCIe link is up
		On	PCIe link is down

Table 9-2 : On Board LEDs

9.2 Temperature and Voltage Sensors

Sensor Number	Signal Type	Signal Monitored
0	Event	Hot-swap switch
1	Temperature	LM75 #1
2	Temperature	LM75 #2
3	Voltage	+12V (PWR)
4	Voltage	+1.5V
5	Voltage	FPGA VCORE
6	Voltage	+3.3V

Table 9-3 : Temperature and Voltage Sensors

9.3 Connectivity

The TAMC863 provides a single x1 2.5 Gbps PCI-Express Link on AMC Port 4. The PCI-Express Interface works with SSC and non SSC PCI-Express Reference Clocks.

10 Installation

10.1 AMC Module Insertion & Hot-Swap

10.1.1 Insertion

Handle	Blue LED	Description
Open (Full extracted)	OFF	Insert Module into slot
Open (Full extracted)	ON	Module is ready to attempt activation
Closed (Pushed all way in)	Long Blink	Hot-Swap Negotiation
Closed (Pushed all way in)	OFF	Module is ready & powered

Table 10-1: AMC Module Insertion

When the blue LED does not go off but remains in the “ON” state, the module FRU (Field Replaceable Unit) information is invalid or the system cannot provide the requested & required power.

10.1.2 Extraction

Handle	Blue LED	Description
Pulled out 1/2	OFF	Request Hot-Swap
Pulled out 1/2	Short Blink	Hot-Swap Negotiation
Pulled out 1/2	ON	Module is ready to be extracted
Open (Full extracted)	ON	Extract Module from slot

Table 10-2: AMC Module Extraction

11 Pin Assignment – I/O Connector

11.1 Front Panel & I/O Connector

Connector part no.: HDRA-EC68LFDT-SL+ (Honda)

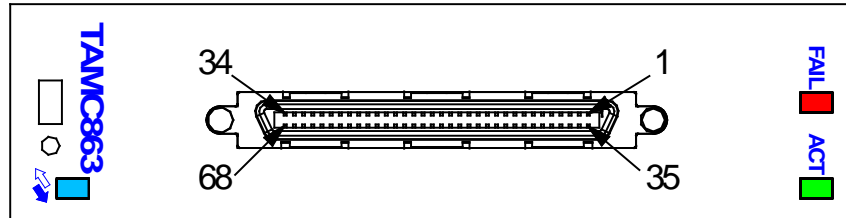

Figure 11-1: Front Panel & I/O Connector

Pin	Signal	Port	Pin	Signal	Port
1	CDA/-	0	35	CDA/-	1
2	CDB/+		36	CDB/+	
3	RXDA/-		37	RXDA/-	
4	RTSA/-		38	RTSA/-	
5	TXDA/-		39	TXDA/-	
6	CTSA/-		40	CTSA/-	
7	RTSB/+		41	RTSB/+	
8	CTSB/+		42	CTSB/+	
9	GND		43	GND	
10	TXDB/+		44	TXDB/+	
11	RXDB/+		45	RXDB/+	
12	TXCA/-		46	TXCA/-	
13	TXCB/+		47	TXCB/+	
14	GND		48	GND	
15	RXCA/-		49	RXCA/-	
16	RXCB/+		50	RXCB/+	
17	CDA/-	2	51	CDA/-	3
18	CDB/+		52	CDB/+	
19	RXDA/-		53	RXDA/-	
20	RTSA/-		54	RTSA/-	
21	TXDA/-		55	TXDA/-	
22	CTSA/-		56	CTSA/-	
23	RTSB/+		57	RTSB/+	
24	CTSB/+		58	CTSB/+	
25	GND		59	GND	
26	TXDB/+		60	TXDB/+	
27	RXDB/+		61	RXDB/+	
28	TXCA/-		62	TXCA/-	
29	TXCB/+		63	TXCB/+	
30	GND		64	GND	
31	RXCA/-		65	RXCA/-	
32	RXCB/+		66	RXCB/+	
33	DSRB/+	3	67	DTRB/+	
34	DSRA/-		68	DTRA/-	

Table 11-1: Front I/O Pin Assignment

In V.28 (single-ended) mode, only the ...A/ signals are used.