

TAMC890 16 Port Gigabit Ethernet Switch

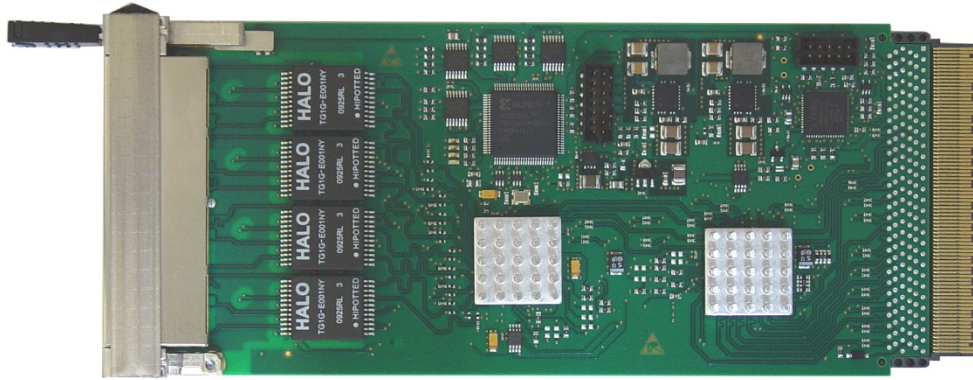

Application Information

The TAMC890 is a standard single width Mid-Size / Full-Size AMC.2 compliant 16 Port gigabit Ethernet Switch.

The TAMC890 supports four RJ45 front panel ports which are compliant to IEEE 802.3ab for 10BaseT, 100BaseTX and IEEE 802.3ab for 1000BaseT via CAT5 TP cable and 12 1.25G-SerDes/SGMII ports which are connected to the AMC backplane connector.

The TAMC890 is AMC.2 Type E2 and Type 4 compliant.

The auto-sensing and auto-negotiation function detect and configure automatically the data rate and the duplex mode.

The functionality of the TAMC890 based on the unmanaged Broadcom BCM5396 Gigabit Ethernet switch. Front panel RJ45 ports are galvanically isolated from the transceiver and switch.

Each channel provides a front panel LEDs to indicate the different network activities.

The operating temperature range is 0°C to +70°C.

Technical Information

- Form Factor: PCIMG AMC.1 Module
 - Board size: 180.6mm x 73.5mm
 - Single width
 - Mid-Size/Full-Size front panel
- Fabric Interface:
 - AMC.2 Type E2 and Type 4 Interface
 - 6 additional GbE Ports on AMC port 12-15, 17 and 18
- IPMI V1.5 Support
- Front Panel LEDs:
 - Blue Hot-Swap LED
 - Red Fail LED (LED1)
 - Green Power LED (LED 2)
- 16 x Link / Status LED
- 4 front panel RJ45 connectors
- 16-Channel 10/100/1000BaseTX Ethernet-Switch Broadcom BCM5396
 - Auto-Sensing und Auto-Negotiation
 - Integrated address management
 - 9KB Jumbo Frames
 - 4K VLAN
- Operating temperature 0°C to +70°C
- MTBF (MIL-HDBK217F/FN2 G_B 20°C)
TAMC890: 5240000h

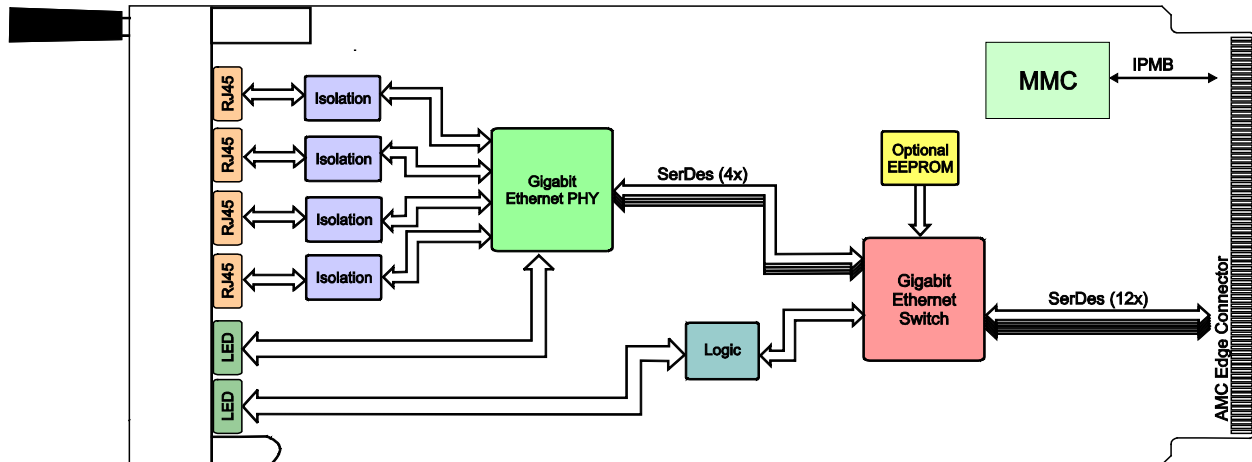

Order Information

RoHS Compliant

TAMC890-10R 16-Ch. Gigabit Ethernet-Switch, BCM5396, Single Mid-Size, 4 x RJ45, 12 x 1.25G-SerDes/SGMII on AMC connector

TAMC890-11R 16-Ch. Gigabit Ethernet-Switch, BCM5396, Single Full-Size, 4 x RJ45, 12 x 1.25G-SerDes/SGMII on AMC connector

For the availability of non-RoHS compliant (lead solder) products please contact TEWS.

Documentation

TAMC890-DOC User Manual