

The Embedded I/O Company



TCPS260

3U CompactPCI Serial PMC Module Carrier

Version 1.0

User Manual

Issue 1.0.1

July 2020

TEWS TECHNOLOGIES GmbH

Am Bahnhof 7 25469 Halstenbek, Germany

Phone: +49 (0) 4101 4058 0 Fax: +49 (0) 4101 4058 19

e-mail: info@tews.com www.tews.com

TCPS260-10R

3U CompactPCI Serial PMC Module Carrier,
PCIe x1

This document contains information, which is proprietary to TEWS TECHNOLOGIES GmbH. Any reproduction without written permission is forbidden.

TEWS TECHNOLOGIES GmbH has made any effort to ensure that this manual is accurate and complete. However TEWS TECHNOLOGIES GmbH reserves the right to change the product described in this document at any time without notice.

TEWS TECHNOLOGIES GmbH is not liable for any damage arising out of the application or use of the device described herein.

Style Conventions

Hexadecimal characters are specified with prefix 0x, i.e. 0x029E (that means hexadecimal value 029E).

For signals on hardware products, an ‚Active Low’ is represented by the signal name with # following, i.e. IP_RESET#.

Access terms are described as:

W	Write Only
R	Read Only
R/W	Read/Write
R/C	Read/Clear
R/S	Read/Set

©2020 by TEWS TECHNOLOGIES GmbH

All trademarks mentioned are property of their respective owners.

Issue	Description	Date
1.0.0	Initial Issue	February 2020
1.0.1	Fixed Typos	July 2020

Table of Contents

1	PRODUCT DESCRIPTION	6
2	TECHNICAL SPECIFICATION	7
3	HANDLING AND OPERATING INSTRUCTIONS	8
3.1	ESD Protection	8
4	PMC INTERFACE	9
4.1	Installation of a PMC Module	9
4.2	PCI Signaling Voltage	9
4.3	PCIe-to-PCI Bridge Header	10
4.4	PCI Bus Device Number Mapping	10
4.5	PCI Clock Frequency	10
4.6	PMC BUSMODE[4:1] Signals	11
4.7	Power Limits for PMC Modules	11
5	INDICATORS	12
5.1	Front Panel LED	12
6	I/O CONNECTORS	13
6.1	Overview	13
6.2	CPCI-S.0 P1 Connector	14
6.3	PMC Connector	14

List of Figures

FIGURE 1-1: BLOCK DIAGRAM.....	6
FIGURE 5-1: FRONT PANEL LED VIEW	12
FIGURE 6-1: CONNECTOR OVERVIEW	13

List of Tables

TABLE 2-1: TECHNICAL SPECIFICATION.....	7
TABLE 4-1: TCPS260 PCI SIGNALING VOLTAGE KEYING.....	9
TABLE 4-2: TCPS260 PCI SIGNALING VOLTAGE FACTORY DEFAULTS	9
TABLE 4-3: PCIE ID CONFIGURATION.....	10
TABLE 4-4: PCI BUS DEVICE NUMBER MAPPING.....	10
TABLE 4-5: TCPS260 PMC BUSMODE[4:1] SIGNALS	11
TABLE 4-6: CURRENT LIMITS FOR THE PMC MODULES.....	11
TABLE 5-1: FRONT PANEL LED.....	12
TABLE 6-1: PERIPHERAL SLOT P1 PIN ASSIGNMENT	14

1 Product Description

The TCPS260 is a PICMG CPCI-S.0 R2.0 compatible 3U module that provides one slot for a single-width PMC module used to build modular, flexible and cost effective I/O solutions for all kinds of applications like process control, medical systems, telecommunication and traffic control. The TCPS260 is a versatile solution to upgrade well known PMC I/O solutions to the CompactPCI Serial standard.

The bridging between the system host board and the PMC slot is handled by the transparent PCIe-to-PCI Bridge XIO2001 from Texas Instruments. The Bridge provides an x1, Rev. 2.0 PCIe link with 2.5 Gbps signaling rate.

On the PMC side, PCI signaling voltages of 3.3V and 5V are supported; 3.3V signaling is default. 32-bit PCI accesses are possible with 33MHz or 66MHz. The TCPS260 supports PMC front-panel I/O.

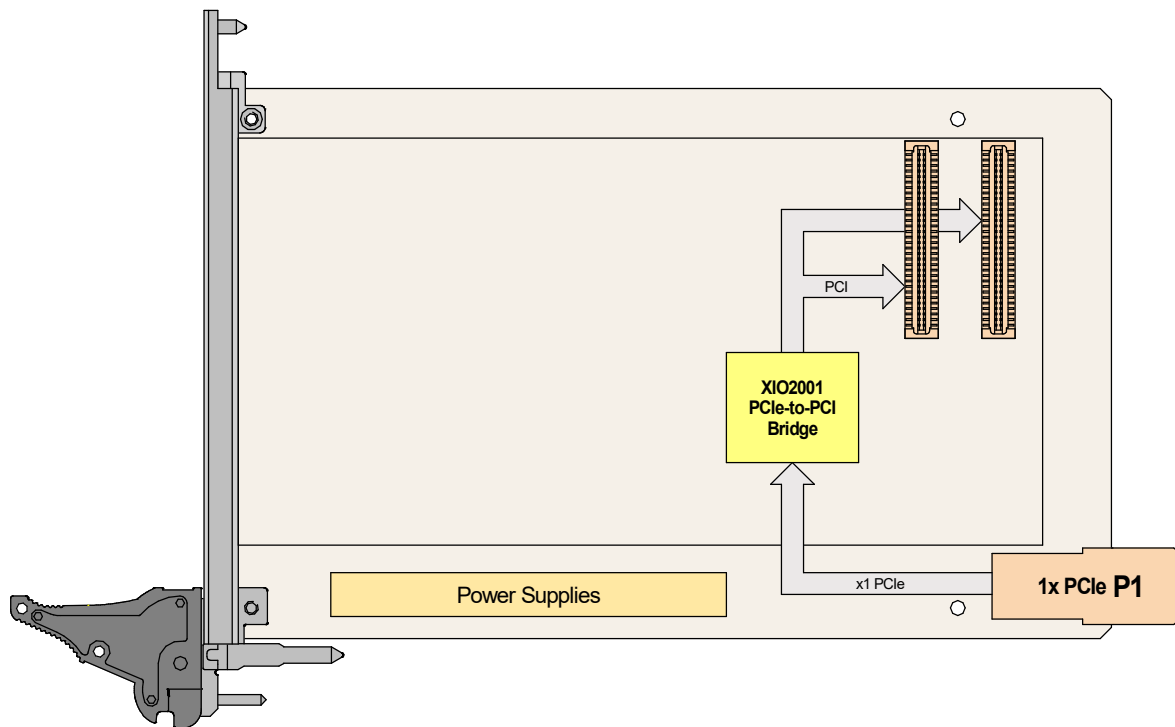

Figure 1-1: Block Diagram

2 Technical Specification

CPCI-S.0 Interface		
Mechanical Interface	Compact Serial 3U Front Board conforming to PICMG CPCI-S.0 R2.0	
Available Interfaces	PCIe: x1 link USB: not supported SATA: not supported I ² C, WAKE, GA[0:3]: not supported	
PMC Interface		
Mechanical Interface	Single Size PCI Mezzanine Card (PMC) conforming to IEEE Std 1386-2001 IEEE Std 1386.1-2001	
PCI Interface	PCI Rev. 2.3 compliant 33/66 MHz / 32 bit PCI 3.3V and 5V PCI Signaling Voltage	
On Board Devices		
PCIe-to-PCI Bridge	XIO2001 (Texas Instruments)	
I/O Interface		
I/O Access	PMC Front Panel I/O	
Physical Data		
Power Requirements	25 mA typical @ +12 V DC (without PMC)	
Available Slot Power	3.3 V: 3 A 5.0 V: 3 A +12 V: Connected to the backplane 12 V supply -12 V: 0.2 A The power supply for the PMC slot is stable approximately 5 ms after the system power supply is stable.	
Temperature Range	Operating	-40°C to +85°C
	Storage	-40°C to +85°C
MTBF	672 000 h MTBF values shown are based on calculation according to MIL-HDBK-217F and MIL-HDBK-217F Notice 2; Environment: G _B 20°C. The MTBF calculation is based on component FIT rates provided by the component suppliers. If FIT rates are not available, MIL-HDBK-217F and MIL-HDBK-217F Notice 2 formulas are used for FIT rate calculation.	
Humidity	5 – 95 % non-condensing	
Weight	118 g	

Table 2-1: Technical Specification

3 Handling and Operating Instructions

3.1 ESD Protection



The TCPS260 module is sensitive to static electricity. Packing, unpacking and all other module handling has to be done in an ESD/EOS protected Area.

4 PMC Interface

4.1 Installation of a PMC Module

The PMC modules are mounted to the TCPS260 prior to installation into the system.

Before installing a PMC module, be sure that the power supply for the TCPS260 is turned off.

The components are Electrostatic Sensitive Devices (ESD). Use an anti-static mat connected to a wristband when handling or installing the components.

If the PMC has a front panel, first remove the cover from the PMC front panel cut-out of the TCPS260. Install the PMC at an angle so that the PMC front panel pushes through the PMC front panel cut-out. Then rotate down to mate with the PMC connectors on the TCPS260. If the PMC has no front panel, simply plug in the PMC, and leave the cover in the PMC front panel cut-out of the TCPS260.

After the PMC module has been installed, it can be secured on the TCPS260 using the mounting screws that come with the PMC module. There are four screw mounting locations, two at the PMC front panel and two at the standoffs near the PMC bus connectors.

4.2 PCI Signaling Voltage

PMC modules are specified either for 3.3V only, 5V only or universal (3.3V or 5V) PCI signaling voltage operation.

The voltage key pin defines the PCI signal voltage level for the TCPS260 PCI bus and prevents PMCs with a wrong signaling voltage from being plugged onto the carrier.

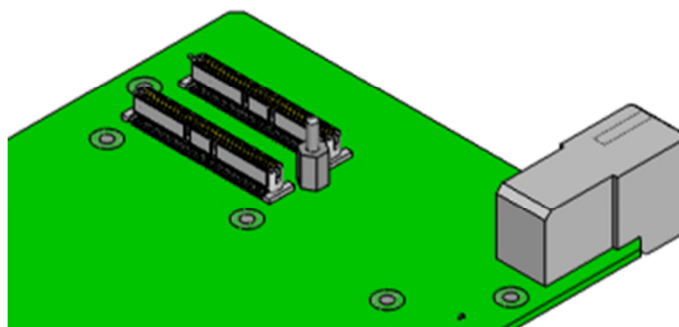

Table 4-1: TCPS260 PCI Signaling Voltage Keying

5V Keying Pin	3.3V Keying Pin	PMC PCI Signaling Voltage		
		5V only	Universal	3.3V only
Installed	Not Installed	✓	✓	✗
Not Installed	Installed	✗	✓	✓

Table 4-2: TCPS260 PCI Signaling Voltage Factory Defaults

As factory default, TCPS260 is assembled with the 3.3 Volt keying pin. To configure the TCPS260 for 5V signaling voltage, install the keying pin on the 5V keying pin position.

4.3 PCIe-to-PCI Bridge Header

ID Type	ID Setting (Description)
Vendor ID	0x104C (Texas Instruments)
Device ID	0x8231 (XIO2001)
Revision ID	0x00
Subsystem ID	0x0000
Subsystem Vendor ID	0x0000
Class Code	0x060400 (PCI-to-PCI Bridge)

Table 4-3: PCIe ID Configuration

4.4 PCI Bus Device Number Mapping

The PCI bus device number of the PMC slot is defined by configuration type translation of the PCI-Express to PCI Bridge.

By default, the PMC slot is mapped to the bus device number 0x0.

PCI Bus Device Number (HEX)	PCI AD Line used as PMC IDSEL	Purpose
0x0	16	Default IDSEL for PMC Slot
0x1	17	Not used on TCPS260
0x2	18	
0x3	19	
0x4	20	Optional IDSEL for PMC Slot
0x5	21	Not used on TCPS260
-	-	
0xF	31	

Table 4-4: PCI Bus Device Number Mapping

4.5 PCI Clock Frequency

The TCPS260 supports 66 MHz PCI clock frequency. The actual PCI clock frequency on the TCPS260 is configured by the plugged PMC module. If the plugged PMC module supports 66 MHz operation, the PCI bus will operate with 66 MHz; otherwise it will operate with 33 MHz.

4.6 PMC BUSMODE[4:1] Signals

The BUSMODE[4:1]# signals are defined in the IEEE1386 (CMC) specification and allow a host to identify the used mezzanine card type. The TCPS260 supports PCI capable cards only.

The TCPS260 indicates the “PMC only” support with the signal levels presented in the table below. The PMC card should decode these signals and drive out a logic “0” on BUSMODE1#.

An onboard LED indicates if a valid PMC is detected.

Signal	Logic Level
BUSMODE4#	Pulled LOW
BUSMODE3#	Pulled LOW
BUSMODE2#	Pulled HIGH

Table 4-5: TCPS260 PMC BUSMODE[4:1] Signals

4.7 Power Limits for PMC Modules

The following current limits have to be taken into account:

TCPS260	Voltage	Current Limits
TCPS260-10R	3.3V	3 A
	5V	3 A
	+12V	200 mA
	-12V	200 mA

Table 4-6: Current Limits for the PMC Modules

The power supply for the PMC slot is stable approximately 5 ms after the system power supply is stable.

5 Indicators

5.1 Front Panel LED

For a quick visual inspection, the TCPS260 module provides a front panel LED.

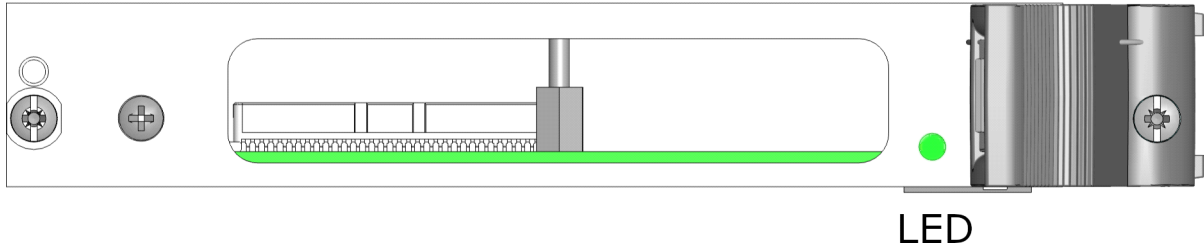

Figure 5-1: Front Panel LED View

LED	Color	State	Description
Front Panel	Red	On	Power Fail
		Off	Power Good, or Power is off
	Green	On	PMC Detected
		Blink	PMC Activity
		Off	No PMC Present, or Power is off

Table 5-1: Front Panel LED

6 I/O Connectors

6.1 Overview

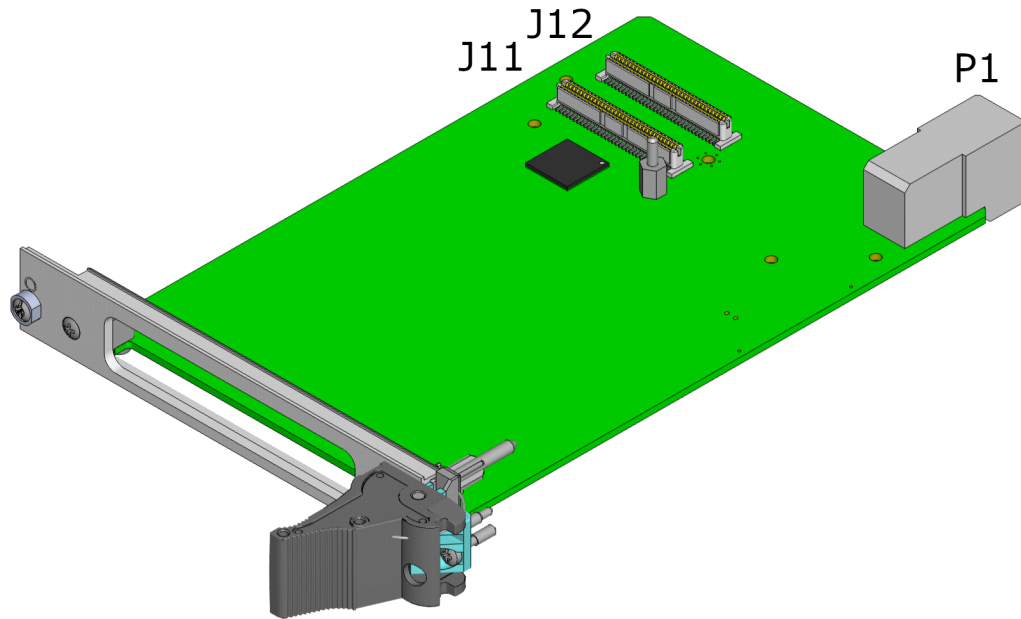

Figure 6-1: Connector Overview

6.2 CPCI-S.0 P1 Connector

Pin	1 - 01	1 - 02	1 - 03	1 - 04	1 - 05	1 - 06
A	+12V	GND	1_USB3_Tx+	GND	1_PE_Tx00+	GND
B	STANDBY	I ² C_SCL	1_USB3_Tx-	1_USB2+	1_PE_Tx00-	1_PE_Tx02+
C	GND	I ² C_SDA	GA0	1_USB2-	GND	1_PE_Tx02-
D	+12V	GND	1_USB3_Rx+	GND	1_PE_Rx00+	GND
E	+12V	reserved	1_USB3_Rx-	PE_CLKIN+	1_PE_Rx00-	1_PE_Rx02+
F	GND	reserved	GA1	PE_CLKIN-	GND	1_PE_Rx02-
G	+12V	GND	SATA_SDI	GND	1_PE_Tx01+	GND
H	+12V	RST#	SATA_SDO	1_SATA_Tx+	1_PE_Tx01-	1_PE_Tx03+
I	GND	WAKE_OUT#	GA2	1_SATA_Tx-	GND	1_PE_Tx03-
J	+12V	GND	SATA_SCL	GND	1_PE_Rx01+	GND
K	+12V	PCIE_EN#	SATA_SL	1_SATA_Rx+	1_PE_Rx01-	1_PE_Rx03+
L	GND	SYSEN#	GA3	1_SATA_Rx-	GND	1_PE_Rx03-

Table 6-1: Peripheral Slot P1 Pin Assignment

6.3 PMC Connector

J11, J12: Refer to the according specifications

J3, J4: Not supported