

The Embedded I/O Company



TIP605

16 Digital Inputs
Optically Isolated

Version 1.1

User Manual

Issue 1.1.4

September 2009

TEWS TECHNOLOGIES GmbH

Am Bahnhof 7 25469 Halstenbek, Germany

Phone: +49 (0) 4101 4058 0 Fax: +49 (0) 4101 4058 19

e-mail: info@tews.com www.tews.com

TIP605

16 digital inputs optically isolated

This document contains information, which is proprietary to TEWS TECHNOLOGIES GmbH. Any reproduction without written permission is forbidden.

TEWS TECHNOLOGIES GmbH has made any effort to ensure that this manual is accurate and complete. However TEWS TECHNOLOGIES GmbH reserves the right to change the product described in this document at any time without notice.

TEWS TECHNOLOGIES GmbH is not liable for any damage arising out of the application or use of the device described herein.

Style Conventions

Hexadecimal characters are specified with prefix 0x, i.e. 0x029E (that means hexadecimal value 029E).

For signals on hardware products, an 'Active Low' is represented by the signal name with # following, i.e. IP_RESET#.

Access terms are described as:

W	Write Only
R	Read Only
R/W	Read/Write
R/C	Read/Clear
R/S	Read/Set

©2009 by TEWS TECHNOLOGIES GmbH

All trademarks mentioned are property of their respective owners.

Issue	Description	Date
1.0	First Issue	May 1997
1.1	General Revision	April 2003
1.2	New address TEWS LLC	September 2006
1.3	Power consumption added to technical specification	June 2008
1.1.4	New hardware version of TIP605 and new notation of User Manual Issue	September 2009

Table of Contents

1	PRODUCT DESCRIPTION	6
2	TECHNICAL SPECIFICATION	7
3	ID PROM CONTENTS.....	8
4	IP ADDRESSING	9
4.1	I/O Addressing.....	9
4.2	Input Data Register	9
4.3	Global Interrupt Control Register	9
4.4	Interrupt Enable Register Rising Edge	10
4.5	Interrupt Enable Register Falling Edge.....	10
4.6	Interrupt Status Register Rising Edge	10
4.7	Interrupt Status Register Falling Edge	11
4.8	Interrupt Vector Register	11
4.9	Debounce Timer Register	11
5	INSTALLATION	12
5.1	Input Wiring	12
6	PIN ASSIGNMENT – I/O CONNECTOR	13
6.1	50 pin I/O flat cable	13
6.2	IP Connector Orientation	14

List of Figures

FIGURE 1-1 : BLOCK DIAGRAM.....	6
FIGURE 5-1 : INPUT WIRING OPTIONS	12
FIGURE 6-1 : IP CONNECTOR ORIENTATION	14

List of Tables

TABLE 2-1 : TECHNICAL SPECIFICATION.....	7
TABLE 3-1 : ID PROM CONTENTS.....	8
TABLE 4-1 : REGISTER SET.....	9
TABLE 4-2 : INPUT DATA REGISTER	9
TABLE 4-3 : GLOBAL INTERRUPT CONTROL REGISTER.....	9
TABLE 4-4 : INTERRUPT ENABLE REGISTER RISING EDGE.....	10
TABLE 4-5 : INTERRUPT ENABLE REGISTER FALLING EDGE	10
TABLE 4-6 : INTERRUPT STATUS REGISTER RISING EDGE.....	10
TABLE 4-7 : INTERRUPT STATUS REGISTER FALLING EDGE	11
TABLE 4-8 : INTERRUPT VECTOR REGISTER.....	11
TABLE 4-9 : DEBOUNCE TIMER REGISTER.....	11
TABLE 6-1 : PIN ASSIGNMENT I/O CONNECTOR.....	13

1 Product Description

The TIP605 is an IndustryPack® compatible module with 16 digital inputs galvanically isolated by optocoupler. The individual inputs are potential free in relation to each other. A high performance input circuit ensures a defined switching point and polarization protection against confusing the pole.

All inputs have an electronic debounce circuit with a freely programmable debounce time. All inputs can generate an interrupt. The signal edge handling is programmable. For the TIP605 the operating temperature range is -40°C to $+85^{\circ}\text{C}$.

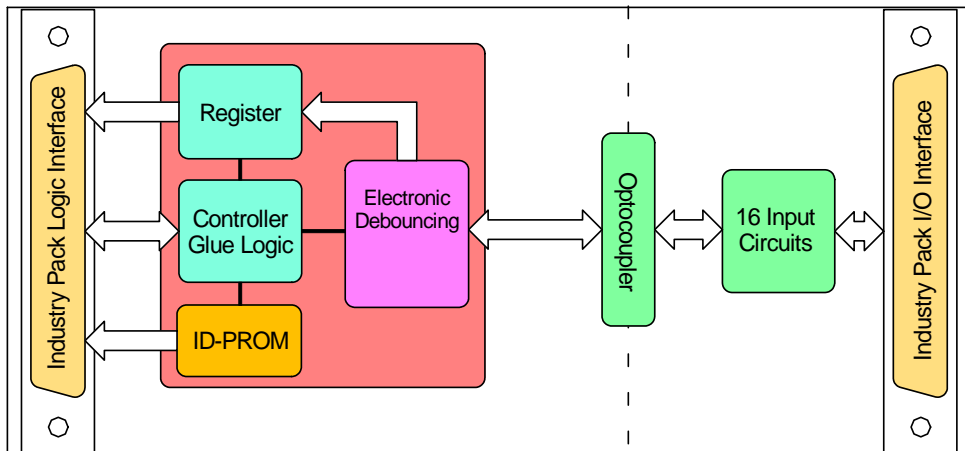

Figure 1-1 : Block Diagram

2 Technical Specification

IP Interface	
Interface	Single Size IndustryPack® Logic Interface compliant to ANSI/VITA 4-1995
ID ROM Data	Format I
I/O Space	Used without wait states
Memory Space	not used
Interrupts	INTREQ0# is used for Input Interrupts INTREQ1# is not used by the TIP605
DMA	Not supported
Clock Rate	8 MHz
Module Type	Type I
I/O Interface	
Inputs	16, each input can generate an interrupt at programmable signal transition
Input Isolation	All channels completely independent from each other
Input Voltage	24V DC
Input Current	4.2mA typical @+24V input voltage
Input Switching Level	12V typical (minimum 7.5, maximum 14V)
Input Signal Debouncing	Electronic debouncing with programmable debounce time (8µs to 261ms in 1.024ms steps common for all inputs)
Interface Connector	50-conductor flat cable
Power Requirements	30mA typical @ +5V DC with 24V Input voltage +12V DC – not used -12V DC – not used
Physical Data	
Temperature Range	Operating -40 °C to +85 °C Storage -40°C to +125°C
MTBF	703000 h MTBF values shown are based on calculation according to MIL-HDBK-217F and MIL-HDBK-217F Notice 2; Environment: G _B 20°C. The MTBF calculation is based on component FIT rates provided by the component suppliers. If FIT rates are not available, MIL-HDBK-217F and MIL-HDBK-217F Notice 2 formulas are used for FIT rate calculation.
Humidity	5 – 95 % non-condensing
Weight	27 g

Table 2-1 : Technical Specification

3 ID PROM Contents

Address	Function	Contents
0x01	ASCII 'I'	0x49
0x03	ASCII 'P'	0x50
0x05	ASCII 'A'	0x41
0x07	ASCII 'C'	0x43
0x09	Manufacturer ID	0xB3
0x0B	Model Number	0x1A
0x0D	Revision	0x10
0x0F	Reserved	0x00
0x11	Driver-ID Low - Byte	0x00
0x13	Driver-ID High - Byte	0x00
0x15	Number of bytes used	0x0D
0x17	CRC	0x1F
0x19	Version	0x0A

Table 3-1 : ID PROM Contents

4 IP Addressing

4.1 I/O Addressing

The complete register set of the TIP605 is accessible in the I/O space of the IP.

Address range: ip_io_base_address + (0x00 to 0x0F)

Address	Symbol	Description	Size (Bit)	Access
0x00	DATAREG	Input Data Register	word	R
0x03	INTCONT	Global Interrupt Control Register	byte	R/W
0x04	INTENALH	Interrupt Enable Rising Edge	word	R/W
0x06	INTENAHL	Interrupt Enable Falling Edge	word	R/W
0x08	INSTATLH	Interrupt Status Rising Edge	word	R/W
0x0A	INTSTATHL	Interrupt Status Falling Edge	word	R/W
0x0D	INTVEC	Interrupt Vector Register	byte	R/W
0x0F	DEBTIME	Debounce Time Register	byte	R/W

Table 4-1 : Register Set

All registers are set to '0' after reset.

4.2 Input Data Register

The Input Data Register is a read only register that reflects the actual states of inputs.

Bit	Symbol	Description	Access	Reset Value
15:0		16 bit input data	R	

Table 4-2 : Input Data Register

4.3 Global Interrupt Control Register

Bit	Symbol	Description	Access	Reset Value
7	Int Req	Global Interrupt Request flag Read as '1' = an interrupt request of at least one of the 16 input channels is pending.	R	
6:1		Not used and undefined during reads		
0	Int Enable	Global Interrupt Enable Bit 1 = globally enables interrupts for all 16 inputs on interrupt request line INTREQ0# of the IP bus	R/W	

Table 4-3 : Global Interrupt Control Register

4.4 Interrupt Enable Register Rising Edge

Bit	Symbol	Description	Access	Reset Value
15:0		Bit 0 enables the interrupt of input channel 1 for the rising edge, bit 15 enables interrupt of input channel 16. All other bits are equivalent. 1 = enabled 0 = disabled	R/W	

Table 4-4 : Interrupt Enable Register Rising Edge

An interrupt request on interrupt request line INTREQ0# of the IP bus is only generated if the global interrupt enable bit of the Global Interrupt Control Register is set to '1'.

4.5 Interrupt Enable Register Falling Edge

Bit	Symbol	Description	Access	Reset Value
15:0		Bit 0 enables the interrupt of input channel 1 for the falling edge, bit 15 enables interrupt of input channel 16. All other bits are equivalent. 1 = enabled 0 = disabled	R/W	

Table 4-5 : Interrupt Enable Register Falling Edge

An interrupt request on interrupt request line INTREQ0# of the IP bus is only generated if the global interrupt enable bit of the Global Interrupt Control Register is set to '1'.

4.6 Interrupt Status Register Rising Edge

Bit	Symbol	Description	Access	Reset Value
15:0		Bit 0 reflects the interrupt request state of input 1 for the rising edge, bit 15 reflects interrupt request of input 16. All other bits are equivalent. Read: 1 = interrupt request pending 0 = no interrupt request pending Write: 1 = clear pending interrupt request for a specific input	R/W	

Table 4-6 : Interrupt Status Register Rising Edge

4.7 Interrupt Status Register Falling Edge

Bit	Symbol	Description	Access	Reset Value
15:0		Bit 0 reflects the interrupt request state of input 1 for the falling edge, bit 15 reflects interrupt request of input 16. All other bits are equivalent. Read: 1 = interrupt request pending 0 = no interrupt request pending Write: 1 = clear pending interrupt request for a specific input	R/W	

Table 4-7 : Interrupt Status Register Falling Edge

4.8 Interrupt Vector Register

Bit	Symbol	Description	Access	Reset Value
7:0		8 bit interrupt vector is loaded by software	R/W	

Table 4-8 : Interrupt Vector Register

4.9 Debounce Timer Register

Bit	Symbol	Description	Access	Reset Value
7:0		Value 0 sets the debounce time to a minimum of 8μs (default after reset). The debounce time can be programmed in steps of 1.024ms in the range of 8μs to 261ms. The debounce time is common for all inputs. $preload\ value = \frac{debounce\ time\ (ms)}{1.024\ (ms)}$	R/W	

Table 4-9 : Debounce Timer Register

5 Installation

5.1 Input Wiring

Each input is optically isolated from the logic circuit. Each input is independent of the other inputs and can be wired different. Each input has two connections at the IP I/O connector, input x+ and input x-. All inputs are isolated by optocoupler and against each other. The input channels can be activated only in one polarity and have an external diode to prevent damage of the optocoupler by wiring the input in a wrong direction.

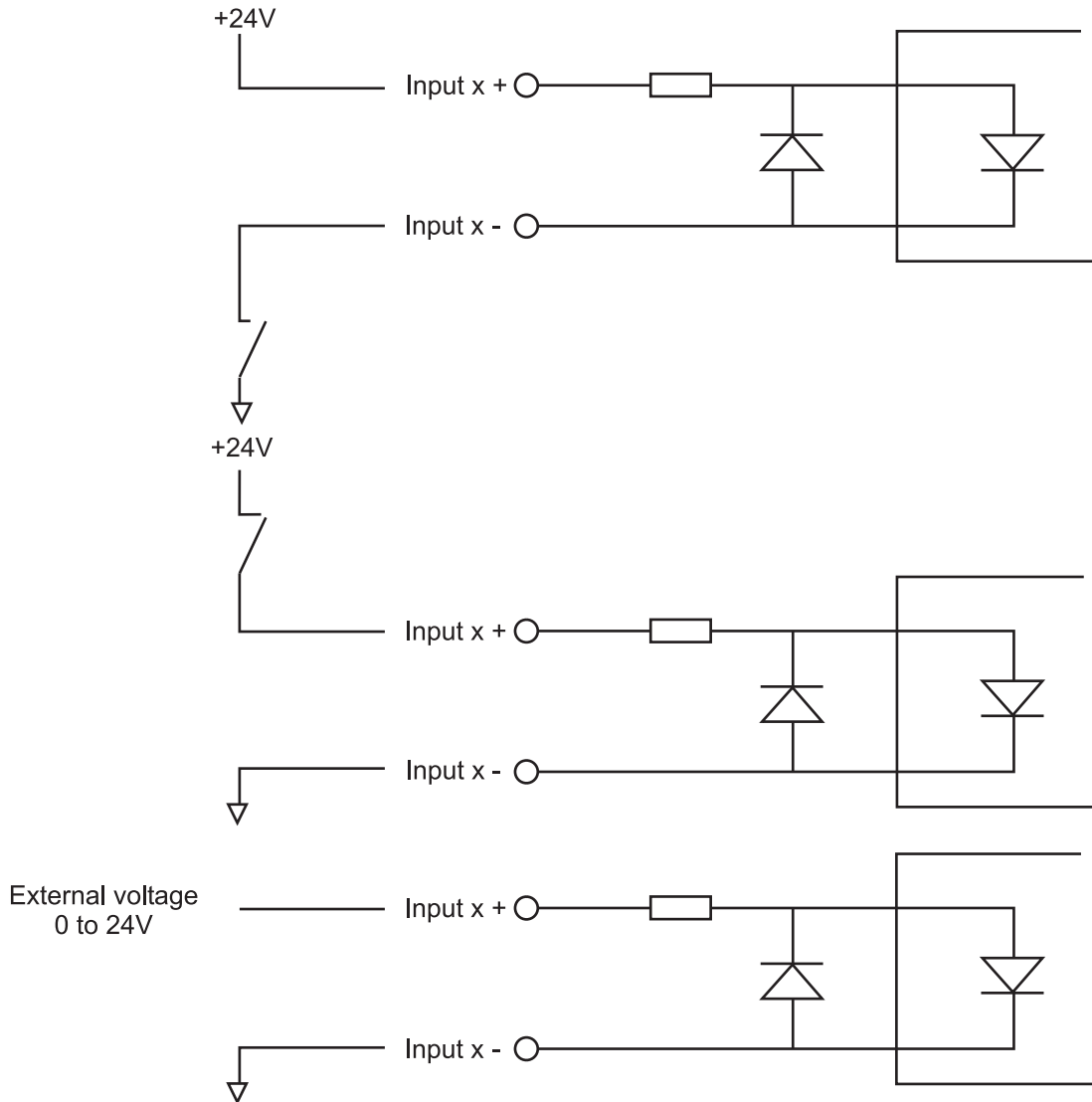

Figure 5-1 : Input Wiring Options

6 Pin Assignment – I/O Connector

6.1 50 pin I/O flat cable

Pin	Signal	Pin	Signal
1	Input 1 +	26	Input 13 -
2	Input 1 -	27	Input 14 +
3	Input 2 +	28	Input 14 -
4	Input 2 -	29	Input 15 +
5	Input 3 +	30	Input 15 -
6	Input 3 -	31	Input 16 +
7	Input 4 +	32	Input 16 -
8	Input 4 -	33	-
9	Input 5 +	34	-
10	Input 5 -	35	-
11	Input 6 +	36	-
12	Input 6 -	37	-
13	Input 7 +	38	-
14	Input 7 -	39	-
15	Input 8 +	40	-
16	Input 8 -	41	-
17	Input 9 +	42	-
18	Input 9 -	43	-
19	Input 10 +	44	-
20	Input 10 -	45	-
21	Input 11 +	46	-
22	Input 11 -	47	-
23	Input 12 +	48	-
24	Input 12 -	49	-
25	Input 13 +	50	-

Table 6-1 : Pin Assignment I/O Connector

6.2 IP Connector Orientation

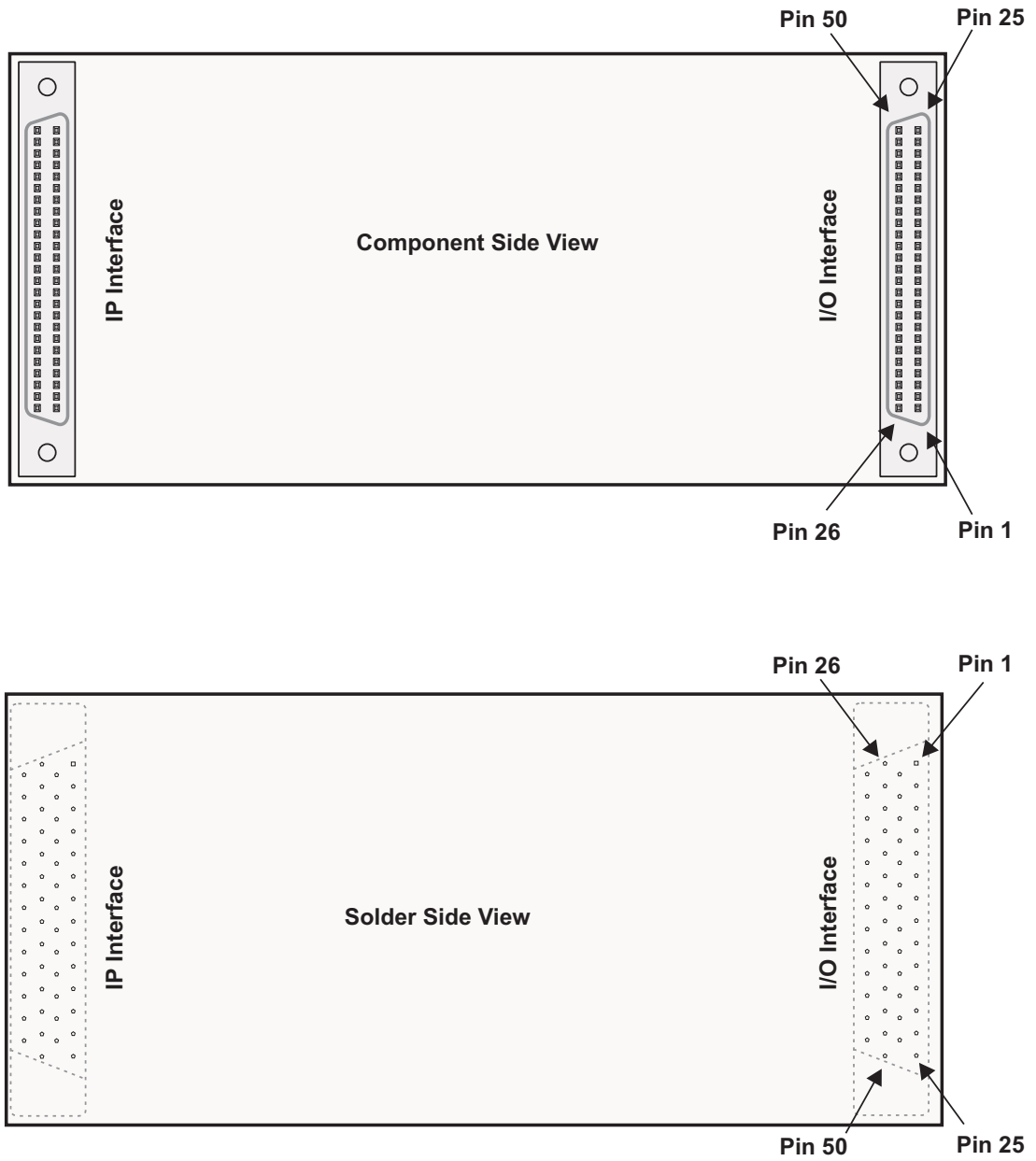

Figure 6-1 : IP Connector Orientation