

*The Embedded I/O Company*



---

# TPCE275

## PCI Express XMC Carrier

Version 1.0

### User Manual

Issue 1.0.3

January 2022

---

**TEWS TECHNOLOGIES GmbH**

Am Bahnhof 7 25469 Halstenbek, Germany

Phone: +49 (0) 4101 4058 0 Fax: +49 (0) 4101 4058 19

e-mail: [info@tews.com](mailto:info@tews.com) [www.tews.com](http://www.tews.com)

## TPCE275-10R

PCI Express x1 Carrier for one XMC module, +12V Power Supply from PCIe Connector, 12V VPWR, J14 I/O, J16 I/O, JTAG connections to XMC module via 10-pin header

## TPCE275-11R

PCI Express x1 Carrier for one XMC module, +12V Power Supply from PCIe Connector, 5V VPWR, J14 I/O, J16 I/O, JTAG connections to XMC module via 10-pin header

## TPCE275-20R

PCI Express x1 Carrier for one XMC module, +12V power supply from external PCIe graphics power connector used, 12V VPWR, J14 I/O, J16 I/O, JTAG connections to XMC module via 10-pin header

## TPCE275-21R

PCI Express x1 Carrier for one XMC module, +12V power supply from external PCIe graphics power connector used, 5V VPWR, J14 I/O, J16 I/O, JTAG connections to XMC module via 10-pin header

This document contains information, which is proprietary to TEWS TECHNOLOGIES GmbH. Any reproduction without written permission is forbidden.

TEWS TECHNOLOGIES GmbH has made any effort to ensure that this manual is accurate and complete. However TEWS TECHNOLOGIES GmbH reserves the right to change the product described in this document at any time without notice.

TEWS TECHNOLOGIES GmbH is not liable for any damage arising out of the application or use of the device described herein.

### Style Conventions

Hexadecimal characters are specified with prefix 0x, i.e. 0x029E (that means hexadecimal value 029E).

For signals on hardware products, an 'Active Low' is represented by the signal name with # following, i.e. IP\_RESET#.

Access terms are described as:

W	Write Only
R	Read Only
R/W	Read/Write
R/C	Read/Clear
R/S	Read/Set

©2022 by TEWS TECHNOLOGIES GmbH

All trademarks mentioned are property of their respective owners.

Issue	Description	Date
1.0.0	Initial Issue	September 2012
1.0.1	Added information about the stable time for the XMC slot power supply	October 2012
1.0.2	New board revision: <ul style="list-style-type: none"> <li>- Modification of power supply voltages on connectors X5 and X6:               <ul style="list-style-type: none"> <li>o VPWR no longer available, is now always +12V</li> <li>o Additionally, +5V are now also available on X6 in TPCE275-x1 variants</li> <li>o All voltages are now fuse protected</li> </ul> </li> </ul>	April 2013
1.0.3	<ul style="list-style-type: none"> <li>• Order Options -2xR: removed the PCIe VGA power connector adapter cable</li> <li>• Added XMC J16 Pinout</li> </ul>	January 2022

# Table of Contents

<b>1</b>	<b>PRODUCT DESCRIPTION .....</b>	<b>6</b>
<b>2</b>	<b>TECHNICAL SPECIFICATION .....</b>	<b>7</b>
<b>3</b>	<b>HANDLING AND OPERATING INSTRUCTIONS .....</b>	<b>8</b>
3.1	ESD Protection .....	8
3.2	Power Limits for XMC Modules .....	8
3.3	Installation of XMC Modules .....	8
3.4	Installation of TPCE275-2xR .....	8
3.5	Installation of TPCE275-x0R .....	8
<b>4</b>	<b>XMC INTERFACE .....</b>	<b>9</b>
4.1	Power Limits for XMC Modules .....	9
4.2	Stable Power Supply.....	9
4.3	Installation of an XMC Module.....	9
<b>5</b>	<b>INDICATORS .....</b>	<b>10</b>
5.1	LED Indicators.....	10
<b>6</b>	<b>PIN ASSIGNMENTS .....</b>	<b>11</b>
6.1	XMC J15 .....	11
6.2	XMC J16 .....	12
6.3	XMC J14 Rear-I/O (X4 - VG64 Connector).....	13
6.4	XMC J16 Rear-I/O (50-Pin Flat Cable Connectors) .....	14
6.4.1	X5 - J16 Differential I/O Lines.....	14
6.4.2	X6 - J16 Single-Ended I/O Lines .....	15
6.5	10-Pin JTAG Header (X7).....	16

---

## List of Figures

FIGURE 1-1 : TPCE275 BLOCK DIAGRAM .....	6
FIGURE 5-1 : ONBOARD LED PLACEMENT .....	10

## List of Tables

TABLE 2-1 : TECHNICAL SPECIFICATION .....	7
TABLE 4-1 : CURRENT LIMITS FOR THE XMC MODULES .....	9
TABLE 5-1 : ONBOARD LED DESCRIPTION .....	10
TABLE 6-1 : XMC J15 PIN ASSIGNMENT .....	11
TABLE 6-2 : XMC J16 PIN ASSIGNMENT .....	12
TABLE 6-2 : X4 - J14 I/O PIN ASSIGNMENT .....	13
TABLE 6-3 : X5 - J16 DIFFERENTIAL I/O LINES PIN ASSIGNMENT .....	14
TABLE 6-4 : X6 - J16 SINGLE-ENDED I/O LINES PIN ASSIGNMENT .....	15
TABLE 6-5 : X7 - JTAG HEADER .....	16

# 1 Product Description

The TPCE275 is a standard height PCI Express, Revision 1.1 compatible module that provides one slot for a single-width XMC module used to build modular, flexible and cost effective I/O solutions for all kinds of applications like process control, medical systems, telecommunication and traffic control.

The TPCE275 supports XMC front-panel I/O, and also XMC P14 and P16 Rear-I/O.

XMC P14 Rear-I/O is offered through a VME P2 style connector (IEC 60603-2, Type C). The I/O mapping of P14 complies with VITA-35 (“PMC P4 to VME-P2, Rows A-C mapping”).

XMC P16 Rear-I/O is implemented through two 50 pin, 0.1 inch flat ribbon cable connectors providing access to all P16 I/O lines. The single-ended signals of P16 are all routed to one flat cable connector, while the differential signals are routed to the second connector.

The operating temperature range is 0°C to +70°C.

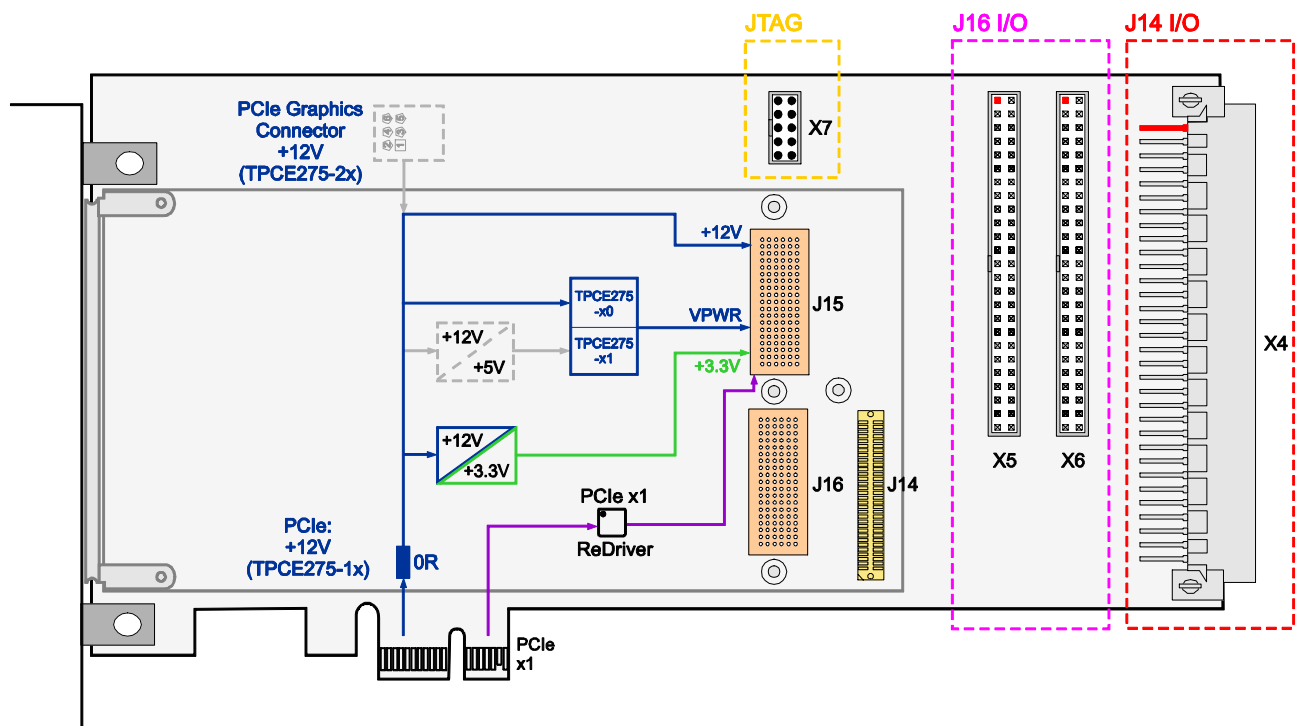

Figure 1-1 : TPCE275 Block Diagram

## 2 Technical Specification

Mechanical and Electrical Interfaces	
PCI Express	PCI Express x1, Revision 1.1 Standard Height Full Length
XMC Slot	ANSI/VITA 42.0 (R2008) ANSI/VITA 42.3 Single-Width
XMC Interface	
Number of XMC Slots	1
XMC I/O Access	XMC Front Panel I/O XMC P14 Rear I/O through VG64 Right Angle Male Connector XMC P16 Rear I/O through 2x50-pin Flat Cable Connectors  Maximum Current for all Rear I/O Lines is 0.5A!
I/O Power Supply Access	+12V, +3.3V and +5V (TPCE275-x1 variants) are available on X5 and X6. All voltages are fuse protected. The maximum current for each voltage is 0.5A!
On Board Devices	
PCI Express ReDriver	PI2EQX4401D (Pericom)
Physical Data	
Power Requirements	125mA maximum @ +3.3V DC 75mA maximum @ +12V DC <b>Additional power is required by the XMC Module!</b>
Power Stable for XMC Slot	The power supply for the XMC slot is stable approximately 20ms after the system power supply is stable.
Maximum Power for XMC Slot	The maximum power available for an XMC module is variant dependent. Please see chapter "Power Limits for XMC Modules" for detailed information.
Temperature Range	Operating    0°C to +70°C Storage       0°C to +70°C
MTBF	TPCE275-1xR: 664000 h TPCE275-2xR: 637000 h MTBF values shown are based on calculation according to MIL-HDBK-217F and MIL-HDBK-217F Notice 2; Environment: G <sub>B</sub> 20°C. The MTBF calculation is based on component FIT rates provided by the component suppliers. If FIT rates are not available, MIL-HDBK-217F and MIL-HDBK-217F Notice 2 formulas are used for FIT rate calculation.
Humidity	5 – 95 % non-condensing
Weight	TPCE275-10R: 114 g TPCE275-11R: 120 g TPCE275-20R: 116 g TPCE275-21R: 122 g

Table 2-1 : Technical Specification

## 3 Handling and Operating Instructions

### 3.1 ESD Protection



The TPCE275 is sensitive to static electricity. Packing, unpacking and all other handling of the TPCE275 has to be done in an ESD/EOS protected Area.

### 3.2 Power Limits for XMC Modules



The PCIe specification limits the power for PCIe add-in cards. These limitations have implications for the use of XMC modules. Refer to the chapter “Power Limits for XMC Modules” for details.

### 3.3 Installation of XMC Modules



Before mounting XMC Modules on the TPCE275, be sure that the system is powered off. Also, follow the installation instructions in the “XMC Interface” chapter.

### 3.4 Installation of TPCE275-2xR



For the TPCE275-2xR variants, it is imperative to always connect a PCI Express VGA power connector to the TPCE275, even if no PMC is mounted.

### 3.5 Installation of TPCE275-x0R



For the TPCE275-x0R variants, VPWR is +12V. This voltage is directly connected from the PCIe connector. The PCIe specification allows for tolerances of  $\pm 8\%$ , whereas the XMC specification allows only for  $\pm 5\%$ .

This has to be taken into consideration before plugging the XMC module onto the TPCE275-x0R.



## 4 XMC Interface

### 4.1 Power Limits for XMC Modules

The following current limits have to be taken into account when choosing the appropriate TPCE275 for the power requirements of the XMC module.

TPCE275	Voltage		Current Limits
TPCE275-1xR	3.3V		2.0 A
	VPWR	5V (TPCE275-11R)	1.2 A
		12V (TPCE275-10R)	0.5 A
	+12V		200 mA
TPCE275-2xR	3.3V		7.5 A
	VPWR	5V (TPCE275-21R)	5.0 A
		12V (TPCE275-20R)	2.1 A
	+12V		200 mA

Table 4-1 : Current Limits for the XMC Modules

### 4.2 Stable Power Supply

The power supply for the XMC slot is stable approximately 20ms after the system power supply is stable.

### 4.3 Installation of an XMC Module

The XMC modules are mounted to the TPCE275 prior to installation into the system.

If the XMC has a front panel, first remove the cover from the XMC front panel cut-out of the TPCE275. Install the XMC at an angle so that the XMC front panel penetrates the XMC front panel cut-out. Then rotate down to mate with the XMC connectors on the TPCE275. If the XMC has no front panel, simply plug in the XMC, and leave the cover in the XMC front panel cut-out of the TPCE275.

After the XMC module has been installed, it can be mounted on the TPCE275 using the mounting screws that come with the XMC module. There are four screw mounting locations, two at the XMC front panel and two at the standoffs near the XMC bus connectors.

**Before installing an XMC module, be sure that the power supply for the TPCE275 is turned off.**

**The components are Electrostatic Sensitive Devices (ESD). Use an anti-static mat connected to a wristband when handling or installing the components.**

# 5 Indicators

## 5.1 LED Indicators

The TPCE275 provides a couple of board-status LEDs as shown below.

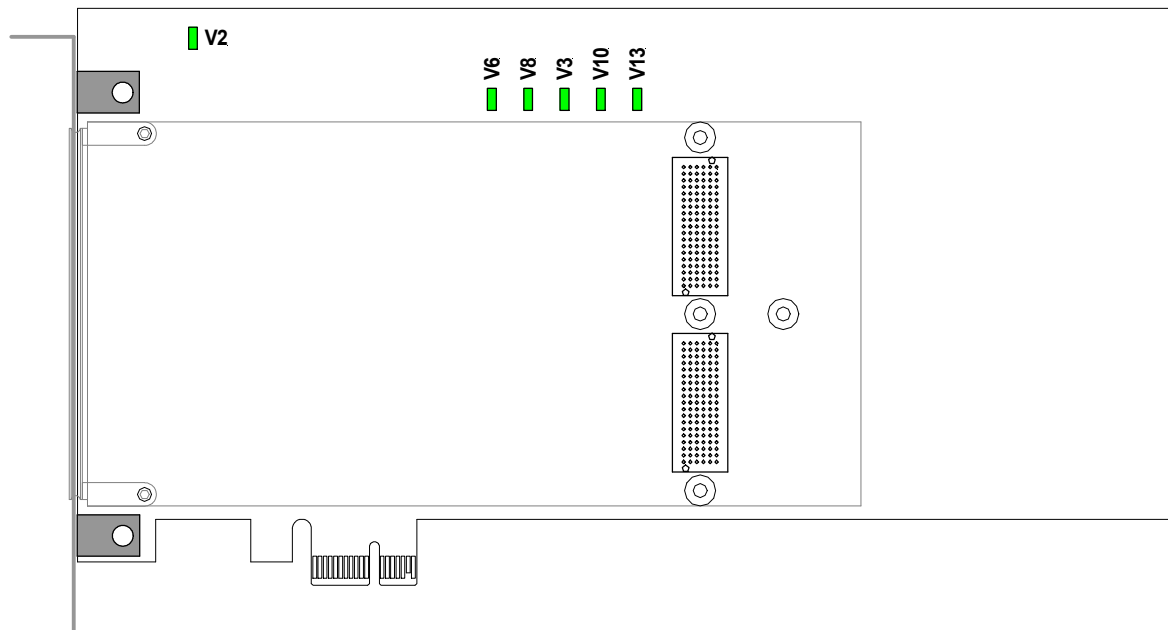

Figure 5-1 : Onboard LED Placement

LED		Color	State	Description
V6	SIG_A	Green	Off	PCIe TX link is down
			On	PCIe TX link is up
V8	SIG_B	Green	Off	PCIe RX link is down
			On	PCIe RX link is up
V2	3.3V Power Good	Green	Off	3.3V Power Supply is not OK
			On	3.3V Power Supply is OK
V3	1.8V Power Good	Green	Off	1.8V Power Supply is not OK
			On	1.8V Power Supply is OK
Dependent on VPWR				
V10	VPWR Power Good	Green	Off	5V Power Supply is not OK
			On	5V Power Supply is OK
V13	VPWR Power Good	Green	Off	12V Power Supply is not OK
			On	12V Power Supply is OK

Table 5-1 : Onboard LED Description

## 6 Pin Assignments

### 6.1 XMC J15

	A	B	C	D	E	F
01	PET0p0	PET0n0	3,3V			VPWR
02	GND	GND	TRST <sup>1)</sup>	GND	GND	PERST#
03			3,3V			VPWR
04	GND	GND	TCK <sup>1)</sup>	GND	GND	
05			3,3V			VPWR
06	GND	GND	TMS <sup>1)</sup>	GND	GND	+12V
07			3,3V			VPWR
08	GND	GND	TDI <sup>1)</sup>	GND	GND	-12V
09						VPWR
10	GND	GND	TDO <sup>1)</sup>	GND	GND	GA0
11	PER0p0	PER0n0				VPWR
12	GND	GND	GA1	GND	GND	
13			3,3V_AUX <sup>2)</sup>			VPWR
14	GND	GND	GA2	GND	GND	SMCLK <sup>6)</sup>
15						VPWR
16	GND	GND	MVMRO <sup>3)</sup>	GND	GND	SMDAT <sup>6)</sup>
17						
18	GND	GND		GND	GND	
19	REFCLK+0	REFCLK-0		WAKE# <sup>4)</sup>	ROOT0# <sup>5)</sup>	

Table 6-1 : XMC J15 Pin Assignment

Notes:

- 1) JTAG lines are routed to a 10pin header onboard, not to the PCIe edge card connector
- 2) 3.3V\_AUX is connected to the PCIe edge card connector, so it is up to the mainboard to deliver this power supply. If a mainboard does not provide this power supply, it can be changed to 3.3V on the TPCE275 with a resistor.
- 3) MVMRO is set to logic high by default, prohibiting write access. It can be changed via a resistor.
- 4) WAKE# is connected to the PCIe edge card connector, so it is up to the mainboard to provide for this signal. If this is not the case, WAKE# may be separated from the mainboard via a resistor.
- 5) ROOT# is not supported; this pin is not connected on the TPCE275 by default. It can be pulled high via a resistor.
- 6) SMCLK and SMDAT are not connected to the PCIe edge card connector by default. Both signals can be connected via series resistors.

## 6.2 XMC J16

	A	B	C	D	E	F
01	DP00+	DP00-	UD_C01	DP01+	DP01-	UD_F01
02	GND	GND	UD_C02	GND	GND	UD_F02
03	DP02+	DP02-	UD_C03	DP03+	DP03-	UD_F03
04	GND	GND	UD_C04	GND	GND	UD_F04
05	DP04+	DP04-	UD_C05	DP05+	DP05-	UD_F05
06	GND	GND	UD_C06	GND	GND	UD_F06
07	DP06+	DP06-	UD_C07	DP07+	DP07-	UD_F07
08	GND	GND	UD_C08	GND	GND	UD_F08
09	DP08+	DP08-	UD_C09	DP09+	DP09-	UD_F09
10	GND	GND	UD_C10	GND	GND	UD_F10
11	DP10+	DP10-	UD_C11	DP11+	DP11-	UD_F11
12	GND	GND	UD_C12	GND	GND	UD_F12
13	DP12+	DP12-	UD_C13	DP13+	DP13-	UD_F13
14	GND	GND	UD_C14	GND	GND	UD_F14
15	DP14+	DP14-	UD_C15	DP15+	DP15-	UD_F15
16	GND	GND	UD_C16	GND	GND	UD_F16
17	DP16+	DP16-	UD_C17	DP17+	DP17-	UD_F17
18	GND	GND	UD_C18	GND	GND	UD_F18
19	DP18+	DP18-	UD_C19	DP19+	DP19-	UD_F19

Table 6-2 : XMC J16 Pin Assignment

## 6.3 XMC J14 Rear-I/O (X4 - VG64 Connector)

The TPCE275 routes the XMC I/O lines to the VG64 connector compliant to VITA-35 (“PMC P4 to VME-P2, Rows A-C mapping”). The actual signal assignment of the XMC P14 connector is XMC specific.

<b>Connector Type</b>	DIN 41612 2.54mm - Right Angle Male Connector - Type C
<b>Source &amp; Order Info</b>	ERNI 384047

Signal	Pin	Connector view	Pin	Signal
I/O 1	c1		a1	I/O 2
I/O 3	c2		a2	I/O 4
I/O 5	c3		a3	I/O 6
I/O 7	c4		a4	I/O 8
I/O 9	c5		a5	I/O 10
I/O 11	c6		a6	I/O 12
I/O 13	c7		a7	I/O 14
I/O 15	c8		a8	I/O 16
I/O 17	c9		a9	I/O 18
I/O 19	c10		a10	I/O 20
I/O 21	c11		a11	I/O 22
I/O 23	c12		a12	I/O 24
I/O 25	c13		a13	I/O 26
I/O 27	c14		a14	I/O 28
I/O 29	c15		a15	I/O 30
I/O 31	c16		a16	I/O 32
I/O 33	c17		a17	I/O 34
I/O 35	c18		a18	I/O 36
I/O 37	c19		a19	I/O 38
I/O 39	c20		a20	I/O 40
I/O 41	c21		a21	I/O 42
I/O 43	c22		a22	I/O 44
I/O 45	c23		a23	I/O 46
I/O 47	c24		a24	I/O 48
I/O 49	c25		a25	I/O 50
I/O 51	c26		a26	I/O 52
I/O 53	c27		a27	I/O 54
I/O 55	c28		a28	I/O 56
I/O 57	c29		a29	I/O 58
I/O 59	c30		a30	I/O 60
I/O 61	c31		a31	I/O 62
I/O 63	c32		a32	I/O 64

Table 6-3 : X4 - J14 I/O Pin Assignment

## 6.4 XMC J16 Rear-I/O (50-Pin Flat Cable Connectors)

### 6.4.1 X5 - J16 Differential I/O Lines

<b>Pin-Count</b>	50
<b>Connector Type</b>	Flat Cable Connector
<b>Source &amp; Order Info</b>	AMP 104340

Pin Assignment				
Description	Pin	Connector View	Pin	Description
DP00-	1		2	DP00+
DP01-	3		4	DP01+
DP02-	5		6	DP02+
DP03-	7		8	DP03+
DP04-	9		10	DP04+
DP05-	11		12	DP05+
DP06-	13		14	DP06+
DP07-	15		16	DP07+
DP08-	17		18	DP08+
DP09-	19		20	DP09+
DP10-	21		22	DP10+
DP11-	23		24	DP11+
DP12-	25		26	DP12+
DP13-	27		28	DP13+
DP14-	29		30	DP14+
DP15-	31		32	DP15+
DP16-	33		34	DP16+
DP17-	35		36	DP17+
DP18-	37		38	DP18+
DP19-	39		40	DP19+
-	41	42	-	
GND	43	44	GND	
GND	45	46	GND	
3.3V <sup>1)</sup>	47	48	3.3V <sup>1)</sup>	
3.3V <sup>1)</sup>	49	50	3.3V <sup>1)</sup>	

Table 6-4 : X5 - J16 Differential I/O Lines Pin Assignment

**1) All voltages are fuse protected. The maximum current for each voltage is 0.5A!**

## 6.4.2 X6 - J16 Single-Ended I/O Lines

<b>Pin-Count</b>	50
<b>Connector Type</b>	Flat Cable Connector
<b>Source &amp; Order Info</b>	AMP 104340

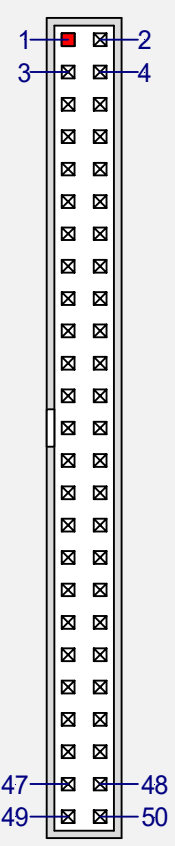
Pin Assignment				
Description	Pin	Connector View	Pin	Description
UD_F1	1		2	UD_C1
UD_F2	3		4	UD_C2
UD_F3	5		6	UD_C3
UD_F4	7		8	UD_C4
UD_F5	9		10	UD_C5
UD_F6	11		12	UD_C6
UD_F7	13		14	UD_C7
UD_F8	15		16	UD_C8
UD_F9	17		18	UD_C9
UD_F10	19		20	UD_C10
UD_F11	21		22	UD_C11
UD_F12	23		24	UD_C12
UD_F13	25		26	UD_C13
UD_F14	27		28	UD_C14
UD_F15	29		30	UD_C15
UD_F16	31		32	UD_C16
UD_F17	33		34	UD_C17
UD_F18	35		36	UD_C18
UD_F19	37		38	UD_C19
+5V <sup>1) 2)</sup>	39		40	+5V <sup>1) 2)</sup>
+5V <sup>1) 2)</sup>	41		42	+5V <sup>1) 2)</sup>
GND	43		44	GND
GND	45		46	GND
+12V_PCl_e <sup>2)</sup>	47		48	+12V_PCl_e <sup>2)</sup>
+12V_PCl_e <sup>2)</sup>	49		50	+12V_PCl_e <sup>2)</sup>

Table 6-5 : X6 - J16 Single-Ended I/O Lines Pin Assignment

- 1) +5V are only available in TPCE275-x1 variants
- 2) All voltages are fuse protected. The maximum current for each voltage is 0.5A!

## 6.5 10-Pin JTAG Header (X7)

The 10-Pin JTAG Header (Connector X7) is connected to the XMC J15 connector with the following pin assignment.

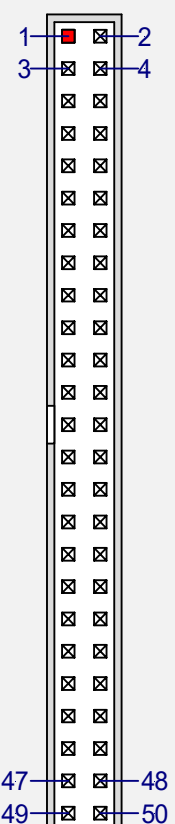
**All pins are described from the perspective of the XMC module.**

Signal	Pin	Connector View	Pin	Signal
TCK	1 *)		2	GND
TMS	3		4	GND
TDO	5		6	GND
TDI	7		8	GND
TRST#	9		10	-

Table 6-6 : X7 - JTAG Header

Notes:

\*) Pin 1 has a squared pad for better recognition