

TPCE277 PCI Express x1, Gen3 XMC Carrier

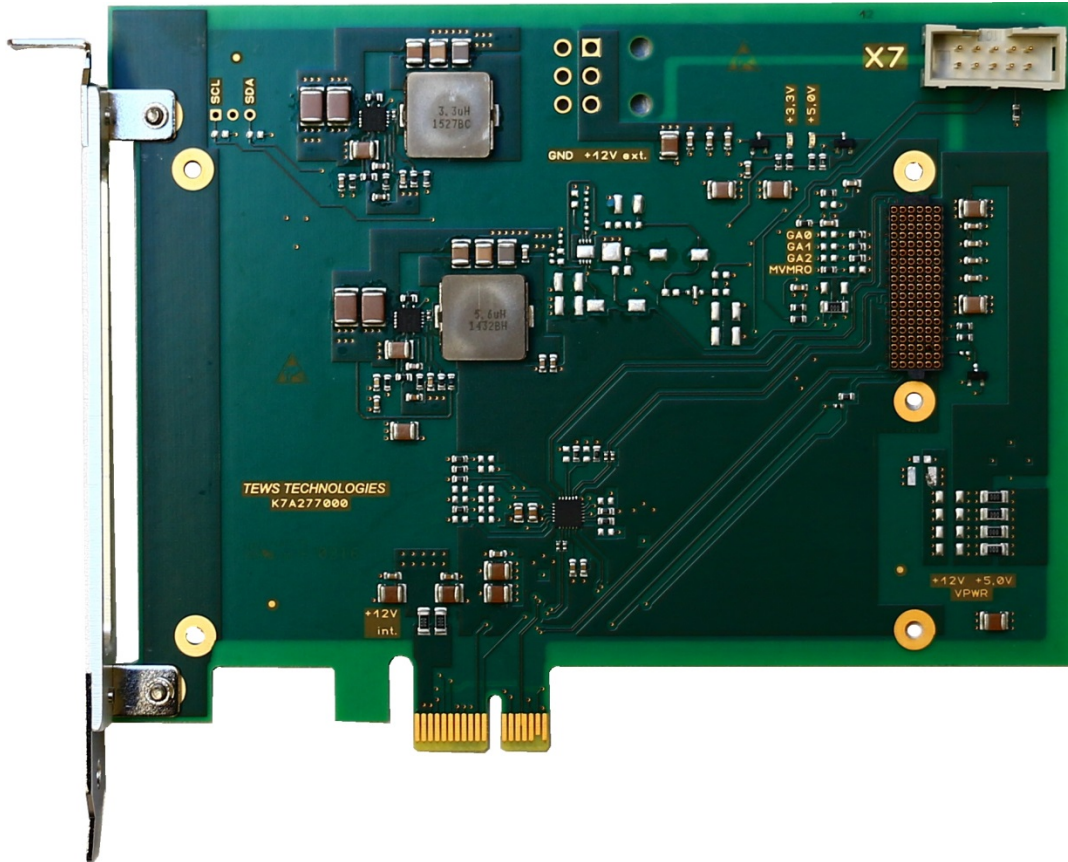

TPCE277-10R

Application Information

The TPCE277 is a standard height PCI Express Revision 3.0 compatible module that provides one slot for a single-width XMC module used to build modular, flexible and cost effective I/O solutions for all kinds of applications like process control, medical systems, telecommunication and traffic control.

The TPCE277 is a versatile solution to upgrade well known XMC I/O solutions to the PCI Express signalling standard.

The PCI Express x1 link from the host board to the XMC module is improved by a PCIe Gen3 Redriver, allowing safe operation of XMC modules on PCIe mainboards.

VPWR is selectable via order option. The TPCE277-x0R variants provide for 12V VPWR and the TPCE277-x1R order options provide 5V VPWR.

The TPCE277 supports XMC front panel I/O.

The PCIe edge card connector provides +12V and +3.3V. The TPCE277-1xR uses the +12V of the PCIe edge card connector to generate all power supply voltages for the XMC slot (+3.3V, VPWR and +12V). According to the PCIe specification, a PCIe x1 card is limited to 6W on the +12V which allows to operate many of the available XMC modules on the TPCE277-1xR.

For increased power requirements of an XMC module, the TPCE277-2xR offer a PCIe Graphics Power Connector to supply the +12V for generating all the power supply voltages for the XMC slot providing power of up to 25W.

A 10-pin JTAG header is available for XMC module debugging purposes. All five JTAG signals are routed directly to the XMC slot.

Technical Information

- Form Factor: PCI Express x1, Revision 3.0
 - Board size: approx. 143mm x 111mm
- One XMC Slot:
 - PCIe Interface: x1, Rev. 3.0
 - XMC Front Panel I/O
- All XMC Power Supplies generated from +12V
 - TPCE277-1xR: +12V from PCIe edge card connector
 - TPCE277-2xR: +12V from PCIe Graphics Power Connector
- JTAG:
 - 10-pin header with all five JTAG signals routed to XMC connector
- Operating temperature: -40°C to +85°C
- MTBF (MIL-HDBK217F/FN2 G_B 20°C):
 - TPCE277-10R: 1764000h
 - TPCE277-11R: 1631000h
 - TPCE277-20R: 1288000h
 - TPCE277-21R: 1216000h

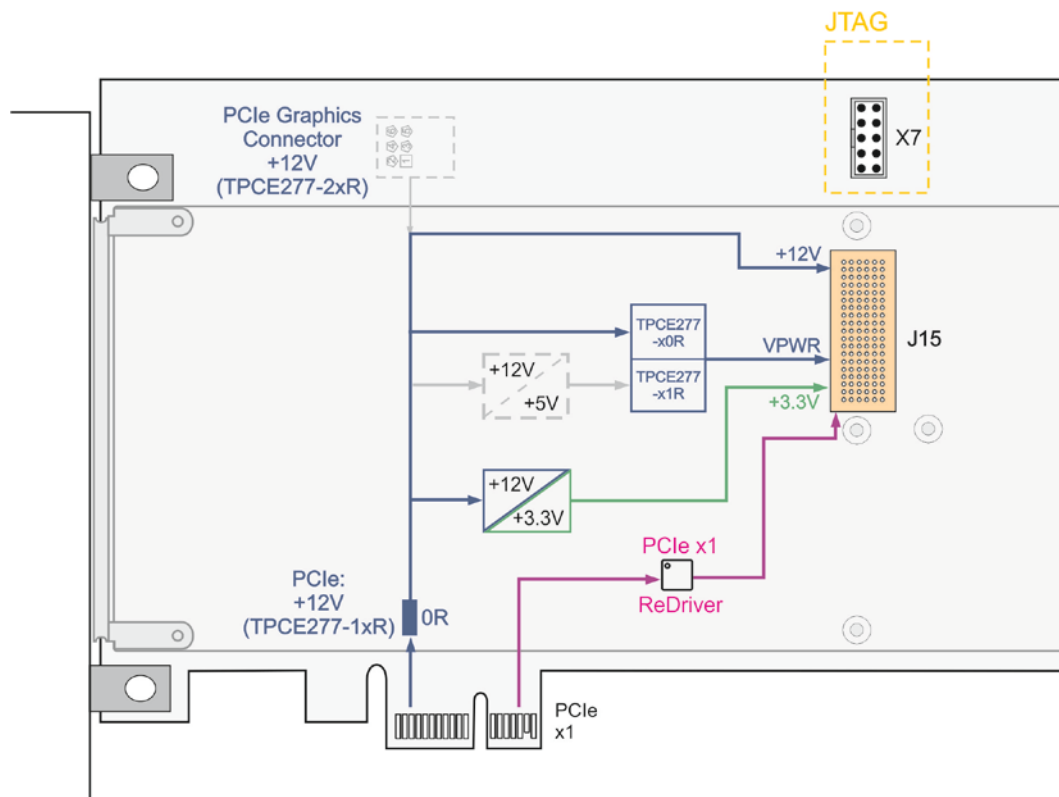

Order Information

RoHS Compliant

- TPCE277-10R** 1 Slot XMC Carrier, PCIe x1, VPWR = 12V, 12V from PCIe connector
- TPCE277-11R** 1 Slot XMC Carrier, PCIe x1, VPWR = 5V, 12V from PCIe connector
- TPCE277-20R** 1 Slot XMC Carrier, PCIe x1, VPWR = 12V, 12V from PCIe Graphics connector
- TPCE277-21R** 1 Slot XMC Carrier, PCIe x1, VPWR = 5V, 12V from PCIe Graphics connector

For the availability of non-RoHS compliant (lead solder) products please contact TEWS.

Documentation

- TPCE277-DOC** User Manual