

The Embedded I/O Company



TPCE277

PCI Express XMC Carrier

Version 1.0

User Manual

Issue 1.0.2

January 2022

TEWS TECHNOLOGIES GmbH

Am Bahnhof 7 25469 Halstenbek, Germany

Phone: +49 (0) 4101 4058 0 Fax: +49 (0) 4101 4058 19

e-mail: info@tews.com www.tews.com

TPCE277-10R

PCI Express x1 Carrier for one XMC module, +12V Power Supply from PCIe Connector, 12V VPWR, JTAG connections to XMC module via 10-pin header

TPCE277-11R

PCI Express x1 Carrier for one XMC module, +12V Power Supply from PCIe Connector, 5V VPWR, JTAG connections to XMC module via 10-pin header

TPCE277-20R

PCI Express x1 Carrier for one XMC module, +12V power supply from external PCIe graphics power connector used, 12V VPWR, JTAG connections to XMC module via 10-pin header

TPCE277-21R

PCI Express x1 Carrier for one XMC module, +12V power supply from external PCIe graphics power connector used, 5V VPWR, JTAG connections to XMC module via 10-pin header

This document contains information, which is proprietary to TEWS TECHNOLOGIES GmbH. Any reproduction without written permission is forbidden.

TEWS TECHNOLOGIES GmbH has made any effort to ensure that this manual is accurate and complete. However TEWS TECHNOLOGIES GmbH reserves the right to change the product described in this document at any time without notice.

TEWS TECHNOLOGIES GmbH is not liable for any damage arising out of the application or use of the device described herein.

Style Conventions

Hexadecimal characters are specified with prefix 0x, i.e. 0x029E (that means hexadecimal value 029E).

For signals on hardware products, an 'Active Low' is represented by the signal name with # following, i.e. IP_RESET#.

Access terms are described as:

W	Write Only
R	Read Only
R/W	Read/Write
R/C	Read/Clear
R/S	Read/Set

©2022 by TEWS TECHNOLOGIES GmbH

All trademarks mentioned are property of their respective owners.

Issue	Description	Date
1.0.0	Initial Issue	February 2016
1.0.1	Removed J14 and J16 I/O from the technical specification table.	February 2016
1.0.2	Order Options -2xR: removed the PCIe VGA power connector adapter cable	January 2022

Table of Contents

1	PRODUCT DESCRIPTION	6
2	TECHNICAL SPECIFICATION	8
3	HANDLING AND OPERATING INSTRUCTIONS	9
3.1	ESD Protection	9
3.2	Power Limits for XMC Modules	9
3.3	Installation of XMC Modules	9
3.4	Installation of TPCE277-2xR	9
3.5	Installation of TPCE277-x0R	9
4	XMC INTERFACE	10
4.1	Power Limits for XMC Modules	10
4.2	Stable Power Supply.....	10
4.3	Installation of an XMC Module.....	10
5	INDICATORS	11
5.1	LED Indicators.....	11
6	PIN ASSIGNMENTS	12
6.1	XMC J15	12
6.2	10-Pin JTAG Header (X7).....	13

List of Figures

FIGURE 1-1 : TPCE277 BLOCK DIAGRAM	7
FIGURE 5-1 : ON-BOARD LED PLACEMENT	11

List of Tables

TABLE 2-1 : TECHNICAL SPECIFICATION	8
TABLE 4-1 : CURRENT LIMITS FOR THE XMC MODULES	10
TABLE 5-1 : ON-BOARD LED DESCRIPTION	11
TABLE 6-1 : XMC J15 PIN ASSIGNMENT	12
TABLE 6-2 : X7 - JTAG HEADER	13

1 Product Description

The TPCE277 is a standard height PCI Express Revision 3.0 compatible module that provides one slot for a single-width XMC module used to build modular, flexible and cost effective I/O solutions for all kinds of applications like process control, medical systems, telecommunication and traffic control.

The TPCE277 is a versatile solution to upgrade well known XMC I/O solutions to the PCI Express signalling standard.

The PCI Express x1 link from the host board to the XMC module is improved by a PCIe Gen3 Redriver, allowing safe operation of XMC modules on PCIe mainboards.

VPWR is selectable via order option. The TPCE277-x0R variants provide for 12V VPWR and the TPCE277-x1R order options provide 5V VPWR.

The TPCE277 supports XMC front panel I/O.

The PCIe edge card connector provides +12V and +3.3V. The TPCE277-1xR uses the +12V of the PCIe edge card connector to generate all power supply voltages for the XMC slot (+3.3V, VPWR and +12V). According to the PCIe specification, a PCIe x1 card is limited to 6W on the +12V which allows to operate many of the available XMC modules on the TPCE277-1xR.

For increased power requirements of an XMC module, the TPCE277-2xR offer a PCIe Graphics Power Connector to supply the +12V for generating all the power supply voltages for the XMC slot providing power of up to 25W.

A 10-pin JTAG header is available for XMC module debugging purposes. All five JTAG signals are routed directly to the XMC slot.

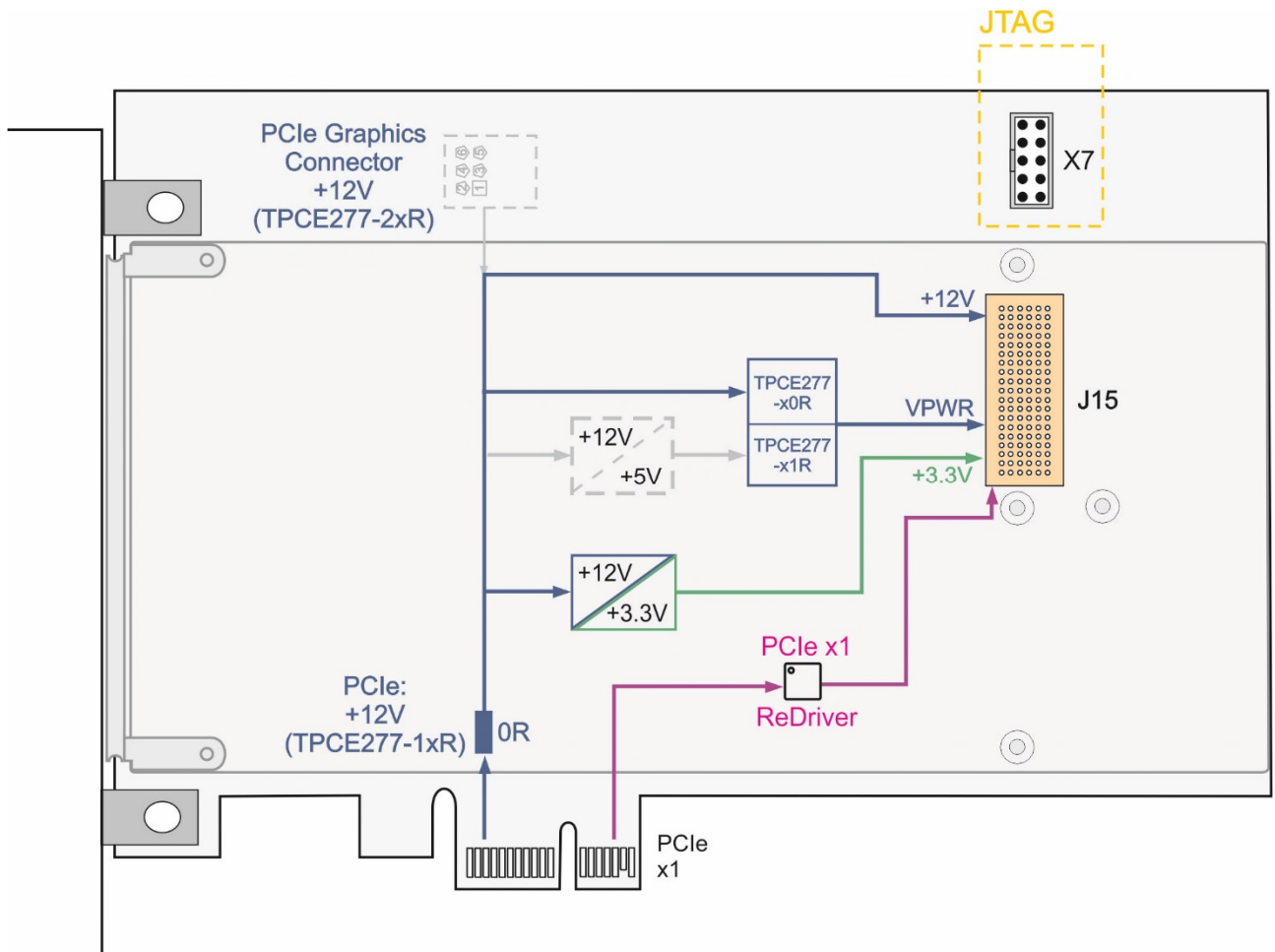

Figure 1-1 : TPCE277 Block Diagram

2 Technical Specification

Mechanical and Electrical Interfaces	
PCI Express	PCI Express x1, Revision 3.0 Standard Height Full Length
XMC Slot	ANSI/VITA 42.0-2008 (R2014) ANSI/VITA 42.3-2006 (R2014) Single-Width
XMC Interface	
Number of XMC Slots	1
XMC I/O Access	XMC Front Panel I/O
On-Board Devices	
PCI Express ReDriver	DS80PCI102 (Texas Instruments)
Physical Data	
Power Requirements	15mA maximum @ +3.3V DC 50mA maximum @ +12V DC Additional power is required by the XMC Module!
Power Stable for XMC Slot	The power supply for the XMC slot is stable approximately 5ms after the system power supply is stable.
Maximum Power for XMC Slot	The maximum power available for an XMC module is variant dependent. Please see chapter “Power Limits for XMC Modules” for detailed information.
Temperature Range	Operating -40°C to +85°C Storage -40°C to +85°C
MTBF	TPCE277-10R: 1764000 h TPCE277-11R: 1631000 h TPCE277-20R: 1288000 h TPCE277-21R: 1216000 h MTBF values shown are based on calculation according to MIL-HDBK-217F and MIL-HDBK-217F Notice 2; Environment: G _B 20°C. The MTBF calculation is based on component FIT rates provided by the component suppliers. If FIT rates are not available, MIL-HDBK-217F and MIL-HDBK-217F Notice 2 formulas are used for FIT rate calculation.
Humidity	5 – 95 % non-condensing
Weight	TPCE277-10R: 75g TPCE277-11R: 79g TPCE277-20R: 77g TPCE277-21R: 81g

Table 2-1 : Technical Specification

3 Handling and Operating Instructions

3.1 ESD Protection



The TPCE277 is sensitive to static electricity. Packing, unpacking and all other handling of the TPCE277 has to be done in an ESD/EOS protected Area.

3.2 Power Limits for XMC Modules



The PCIe specification limits the power for PCIe add-in cards. These limitations have implications for the use of XMC modules. Refer to the chapter “Power Limits for XMC Modules” for details.

3.3 Installation of XMC Modules



Before mounting XMC Modules on the TPCE277, be sure that the system is powered off. Also, follow the installation instructions in the “XMC Interface” chapter.

3.4 Installation of TPCE277-2xR



For the TPCE277-2xR variants, it is imperative to always connect a PCI Express VGA power connector to the TPCE277, even if no PMC is mounted.

3.5 Installation of TPCE277-x0R



For the TPCE277-x0R variants, VPWR is +12V. This voltage is directly connected from the PCIe connector. The PCIe specification allows for tolerances of $\pm 8\%$, whereas the XMC specification allows only for $\pm 5\%$.

This has to be taken into consideration before plugging the XMC module onto the TPCE277-x0R.

4 XMC Interface

4.1 Power Limits for XMC Modules

The following current limits have to be taken into account when choosing the appropriate TPCE277 for the power requirements of the XMC module.

TPCE277	Voltage		Current Limits
TPCE277-1xR	3.3V		2.0 A
	VPWR	5V (TPCE277-11R)	1.2 A
		12V (TPCE277-10R)	0.5 A
	+12V		200 mA
TPCE277-2xR	3.3V		7.5 A
	VPWR	5V (TPCE277-21R)	5.0 A
		12V (TPCE277-20R)	2.1 A
	+12V		200 mA

Table 4-1 : Current Limits for the XMC Modules

4.2 Stable Power Supply

The power supply for the XMC slot is stable approximately 20ms after the system power supply is stable.

4.3 Installation of an XMC Module

The XMC modules are mounted to the TPCE277 prior to installation into the system.

Before installing an XMC module, be sure that the power supply for the TPCE277 is turned off.

The components are Electrostatic Sensitive Devices (ESD). Use an anti-static mat connected to a wristband when handling or installing the components.

If the XMC has a front panel, first remove the cover from the XMC front panel cut-out of the TPCE277. Install the XMC at an angle so that the XMC front panel penetrates the XMC front panel cut-out. Then rotate down to mate with the XMC connectors on the TPCE277. If the XMC has no front panel, simply plug in the XMC, and leave the cover in the XMC front panel cut-out of the TPCE277.

After the XMC module has been installed, it can be mounted on the TPCE277 using the mounting screws that come with the XMC module. There are four screw mounting locations, two at the XMC front panel and two at the standoffs near the XMC bus connectors.

5 Indicators

5.1 LED Indicators

The TPCE277 provides a couple of board-status LEDs as shown below.

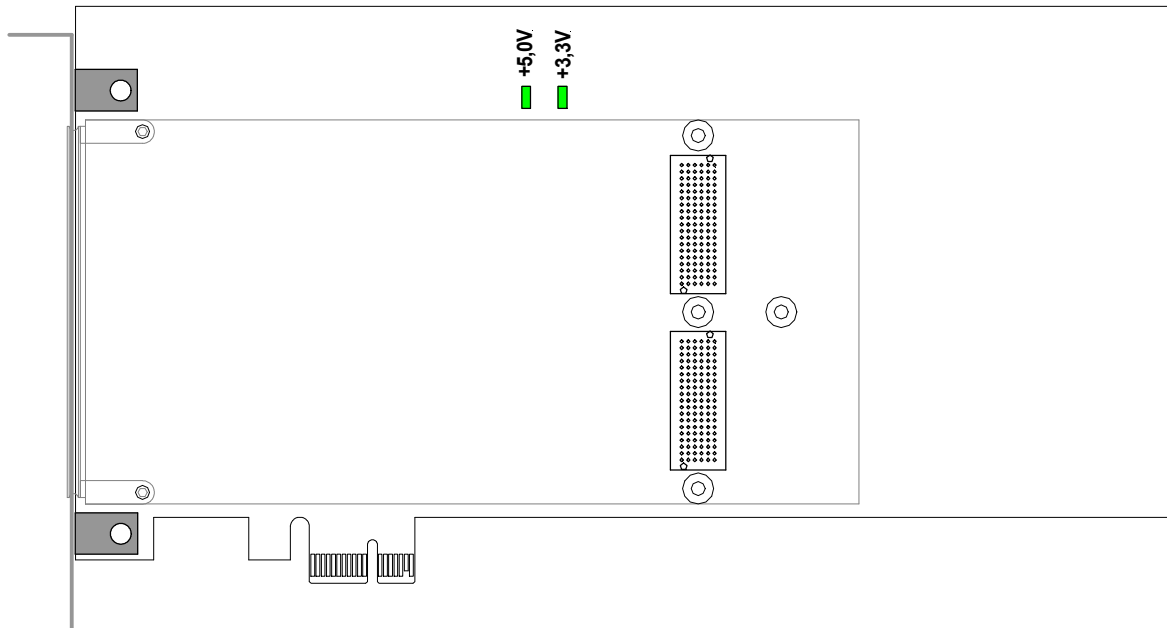

Figure 5-1 : On-board LED Placement

LED		Color	State	Description
+3.3V	3.3V Power Good	Green	Off	3.3V Power Supply is not OK
			On	3.3V Power Supply is OK
+5.0V	5.0V Power Good *)	Green	Off	5.0V Power Supply is not OK
			On	5.0V Power Supply is OK

Table 5-1 : On-board LED Description

*) Only for VPWR = 5V variants

6 Pin Assignments

6.1 XMC J15

	A	B	C	D	E	F
01	PET0p0	PET0n0	3.3V			VPWR
02	GND	GND	TRST ¹⁾	GND	GND	PERST#
03			3.3V			VPWR
04	GND	GND	TCK ¹⁾	GND	GND	
05			3.3V			VPWR
06	GND	GND	TMS ¹⁾	GND	GND	+12V
07			3.3V			VPWR
08	GND	GND	TDI ¹⁾	GND	GND	-12V
09						VPWR
10	GND	GND	TDO ¹⁾	GND	GND	GA0
11	PER0p0	PER0n0				VPWR
12	GND	GND	GA1	GND	GND	
13			3.3V_AUX ²⁾			VPWR
14	GND	GND	GA2	GND	GND	SMCLK ⁶⁾
15						VPWR
16	GND	GND	MVMRO ³⁾	GND	GND	SMDAT ⁶⁾
17						
18	GND	GND		GND	GND	
19	REFCLK+0	REFCLK-0		WAKE# ⁴⁾	ROOT0# ⁵⁾	

Table 6-1 : XMC J15 Pin Assignment

Notes:

- 1) JTAG lines are routed to a 10pin header on-board, not to the PCIe edge card connector
- 2) 3.3V_AUX is connected to the PCIe edge card connector, so it is up to the mainboard to deliver this power supply. If a mainboard does not provide this power supply, it can be changed to 3.3V on the TPCE277 with a resistor.
- 3) MVMRO is set to logic high by default, prohibiting write access. It can be changed via a resistor.
- 4) WAKE# is connected to the PCIe edge card connector, so it is up to the mainboard to provide for this signal. If this is not the case, WAKE# may be separated from the mainboard via a resistor.
- 5) ROOT# is not supported; this pin is not connected on the TPCE277 by default. It can be pulled high via a resistor.
- 6) SMCLK and SMDAT are not connected to the PCIe edge card connector by default. Both signals can be connected via series resistors.

6.2 10-Pin JTAG Header (X7)

The 10-Pin JTAG Header (Connector X7) is connected to the XMC J15 connector with the following pin assignment.

All pins are described from the perspective of the XMC module.

Signal	Pin	Connector View	Pin	Signal
TCK	1 *)		2	GND
TMS	3		4	GND
TDO	5		6	GND
TDI	7		8	GND
TRST#	9		10	-

Table 6-2 : X7 - JTAG Header

Notes:

*) Pin 1 has a squared pad for better recognition