

The Embedded I/O Company



TPCE280

PCI Express x8, Gen3 XMC Carrier

Version 1.0

User Manual

Issue 1.0.3

January 2022

TEWS TECHNOLOGIES GmbH

Am Bahnhof 7 25469 Halstenbek, Germany

Phone: +49 (0) 4101 4058 0 Fax: +49 (0) 4101 4058 19

e-mail: info@tews.com www.tews.com

TPCE280-10R

PCI Express x8 Carrier for one XMC module, +12V Power Supply from PCIe Connector, 12V VPWR, J14 I/O, J16 I/O, JTAG connections to XMC module via 14-pin header

TPCE280-11R

PCI Express x8 Carrier for one XMC module, +12V Power Supply from PCIe Connector, 5V VPWR, J14 I/O, J16 I/O, JTAG connections to XMC module via 14-pin header

TPCE280-20R

PCI Express x8 Carrier for one XMC module, +12V power supply from external PCIe graphics power connector used, 12V VPWR, J14 I/O, J16 I/O, JTAG connections to XMC module via 14-pin header

TPCE280-21R

PCI Express x8 Carrier for one XMC module, +12V power supply from external PCIe graphics power connector used, 5V VPWR, J14 I/O, J16 I/O, JTAG connections to XMC module via 14-pin header

This document contains information, which is proprietary to TEWS TECHNOLOGIES GmbH. Any reproduction without written permission is forbidden.

TEWS TECHNOLOGIES GmbH has made any effort to ensure that this manual is accurate and complete. However TEWS TECHNOLOGIES GmbH reserves the right to change the product described in this document at any time without notice.

TEWS TECHNOLOGIES GmbH is not liable for any damage arising out of the application or use of the device described herein.

Style Conventions

Hexadecimal characters are specified with prefix 0x, i.e. 0x029E (that means hexadecimal value 029E).

For signals on hardware products, an 'Active Low' is represented by the signal name with # following, i.e. IP_RESET#.

Access terms are described as:

W	Write Only
R	Read Only
R/W	Read/Write
R/C	Read/Clear
R/S	Read/Set

©2022 by TEWS TECHNOLOGIES GmbH

All trademarks mentioned are property of their respective owners.

Issue	Description	Date
1.0.0	Initial Issue	December 2018
1.0.1	Added 3D model figures to show the positions of the JTAG rotary switch and the LEDs	March 2018
1.0.2	Corrected the J15 pinout table to x8 pinout, was x4	September 2020
1.0.3	Order Options -2xR: removed the PCIe VGA power connector adapter cable	January 2022

Table of Contents

1	PRODUCT DESCRIPTION	6
2	TECHNICAL SPECIFICATION	7
3	HANDLING AND OPERATING INSTRUCTIONS	8
3.1	ESD Protection	8
3.2	Installation of TPCE280-2xR	8
4	XMC INTERFACE	9
4.1	Power	9
4.1.1	VPWR Tolerance	9
4.1.2	Power Limits for XMC Modules	9
4.1.3	Stable Power Supply	10
4.2	Installation of an XMC Module.....	10
5	JTAG	11
5.1	USB Type C Connector	11
5.2	JTAG voltage for XMC Module	11
6	INDICATORS	12
6.1	LED Indicators.....	12
7	PIN ASSIGNMENTS	13
7.1	XMC J15	13
7.2	XMC J16 I/O Connector	14
7.2.1	X5 – Firefly Micro Flyover Connector #1	14
7.2.2	X6 – Firefly Micro Flyover Connector #2	16
7.3	XMC J14 I/O Connector	18
7.4	X8 - 14-Pin JTAG Header	19
7.5	X3 – PCIe VGA Graphics Power Connector	20

List of Figures

FIGURE 1-1 : TPCE280 BLOCK DIAGRAM.....	6
FIGURE 5-1 : JTAG VOLTAGE ROTARY SELECTOR SWITCH LOCATION, MARKED RED (TOP VIEW OF TPCE280).....	11
FIGURE 6-1 : ON-BOARD LED PLACEMENT	12

List of Tables

TABLE 2-1 : TECHNICAL SPECIFICATION.....	7
TABLE 4-1 : CURRENT LIMITS FOR THE XMC MODULES.....	9
TABLE 5-1 : ROTARY SELECTOR SWITCH CONFIGURATION.....	11
TABLE 6-1 : ON-BOARD LED DESCRIPTION	12
TABLE 7-1 : XMC J15 PIN ASSIGNMENT	13
TABLE 7-2 : PIN ASSIGNMENT X5 UEC5.....	14
TABLE 7-3 : PIN ASSIGNMENT X5 UCC8.....	15
TABLE 7-4 : PIN ASSIGNMENT X6 UEC5.....	16
TABLE 7-5 : PIN ASSIGNMENT X6 UCC8.....	17
TABLE 7-6 : X4 - J14 I/O PIN ASSIGNMENT.....	18
TABLE 7-7 : X5 – 14-PIN JTAG HEADER PIN ASSIGNMENT	19
TABLE 7-8 : X3 – 6-PIN AUXILLIARY POWER CONNECTOR	20

1 Product Description

The TPCE280 is a standard height, half length PCI Express Revision 3.0 compatible module that provides one slot for a single-width XMC module used to build modular, flexible and cost effective I/O solutions for all kinds of applications like process control, medical systems, telecommunication and traffic control.

The PCI Express x8 link from the host board to the XMC module is enhanced by a PCIe Gen3 Redriver, allowing safe operation of XMC modules on PCIe mainboards.

The voltage level for the XMC's main power supply, VPWR, is selectable via order option. The TPCE280-x0R variants provide 12V VPWR and the TPCE280-x1R order options provide 5V VPWR.

The TPCE280 supports XMC front panel I/O, and also P14 and P16 rear I/O independently.

XMC P14 Rear-I/O is offered through an 68-pin ERNI SMC, right angle male, 1.27mm pitch connector. The I/O lines are routed differential.

XMC P16 Rear-I/O is implemented through two Samtec Firefly UCC8 and UEC5 connectors providing access to the P16 I/O lines.

The TPCE280 provides a fan mounted under the XMC slot that helps cooling the system. This fan does not occupy a second PCIe slot as most other carrier solutions do.

The PCIe edge card connector provides +12V and +3.3V. The TPCE280-1xR uses only the +12V of the PCIe edge card connector to generate all power supply voltages for the XMC slot (+3.3V, VPWR and +12V).

According to the PCIe specification, a PCIe x8 card is allowed to use 25W on its +12V supply which allows to operate most of the available XMC modules on the TPCE280-1xR. For XMC modules with increased power requirements, the TPCE280-2xR offer a PCIe Graphics Power Connector to supply XMCs with up to 75W.

A 14-pin 2mm JTAG header is available for XMC module debugging purposes. All five JTAG signals are routed directly to the XMC slot.

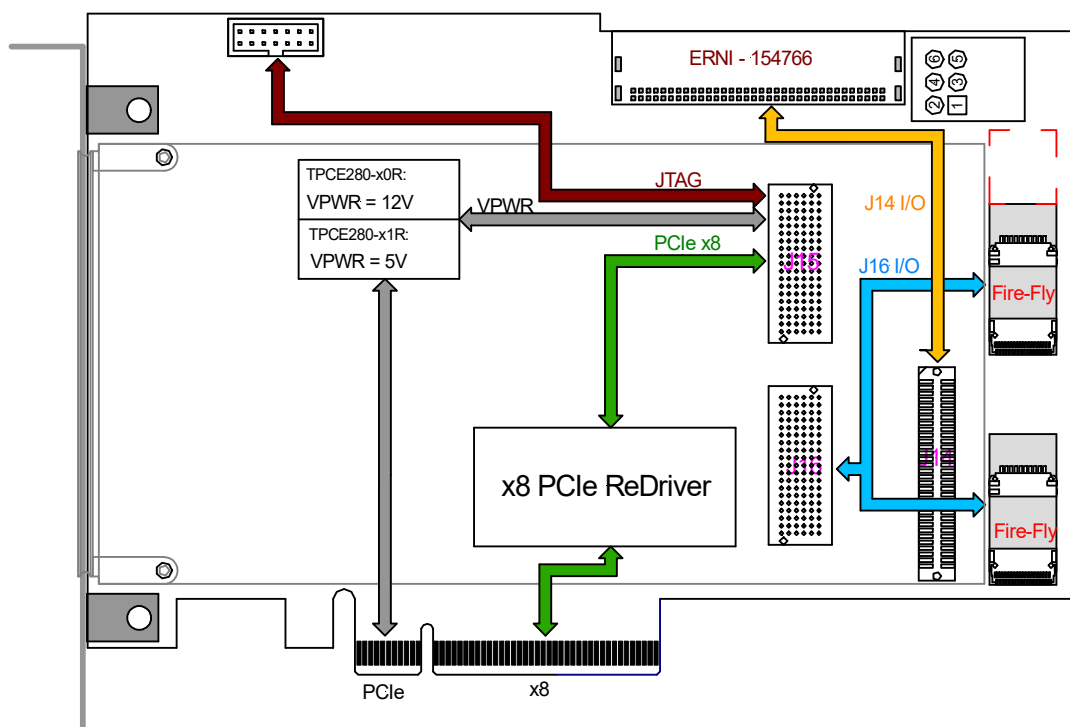

Figure 1-1 : TPCE280 Block Diagram

2 Technical Specification

Mechanical and Electrical Interfaces	
PCI Express	PCI Express x8, Revision 3.0 Standard Height Half-Length
XMC Slot	ANSI/VITA 42.0-2008 (R2014) ANSI/VITA 42.3-2006 (R2014) Single-Width
XMC Interface	
Number of XMC Slots	1
XMC I/O Access	XMC Front Panel I/O XMC P14 Rear-I/O through 68-pin ERNI SMC, right angle male, 1.27mm pitch connector XMC P16 Rear-I/O through two Samtec SAMTEC UCC8 and UEC5 connectors Maximum Current for Rear I/O Lines is 0.5A!
On-Board Devices	
PCI Express ReDriver	2x DS80PCI810 (Texas Instruments)
Physical Data	
Power Requirements	- @ +3.3V DC 180mA maximum @ +12V DC Additional power is required by the XMC Module!
Power Stable for XMC Slot	The power supply for the XMC slot is stable approximately 5ms after the system power supply is stable.
Maximum Power for XMC Slot	The maximum power available for an XMC module is variant dependent. Please see chapter "Power Limits for XMC Modules" for detailed information.
Temperature Range	Operating -40°C to +85°C Storage -40°C to +85°C
MTBF	TPCE280: 344000h MTBF values shown are based on calculation according to MIL-HDBK-217F and MIL-HDBK-217F Notice 2; Environment: G _B 20°C. The MTBF calculation is based on component FIT rates provided by the component suppliers. If FIT rates are not available, MIL-HDBK-217F and MIL-HDBK-217F Notice 2 formulas are used for FIT rate calculation.
Humidity	5 – 95 % non-condensing
Weight	TPCE280: 98 g

Table 2-1 : Technical Specification

3 Handling and Operating Instructions

3.1 ESD Protection



The TPCE280 is sensitive to static electricity. Packing, unpacking and all other handling of the TPCE280 has to be done in an ESD/EOS protected Area.

3.2 Installation of TPCE280-2xR



For the TPCE280-2xR variants, it is imperative to always connect a PCI Express VGA power connector to the TPCE280, even if no XMC is mounted.

4 XMC Interface

4.1 Power

The TPCE280 can provide the following power supplies to the XMC:

- VPWR (12V or 5V)
- 3.3V
- +12V (optional XMC voltage, but always supplied by the TPCE280)
- -12V (optional XMC voltage, available via order option)

As the $\pm 12V$ supplies are optional and VPWR can be 12V or 5V, it depends on the TPCE280 order option which supplies are available and what voltage level is provided as VPWR.

4.1.1 VPWR Tolerance

For all TPCE280 variants with VPWR = 12V, this voltage is directly connected to the 12V supply from the system (either via PCIe edge connector or the PCIe VGA Graphics connector). The PCIe specification allows for tolerances of $\pm 8\%$, whereas the XMC specification allows only for $\pm 5\%$.

This has to be taken into consideration when using these TPCE280 variants.

4.1.2 Power Limits for XMC Modules

The following current limits have to be taken into account when choosing the appropriate TPCE280 for the power requirements of the XMC module.

TPCE280	Voltage		Current Limits *)
TPCE280-1xR	3.3V		3 A
	VPWR	12V (TPCE280-10R)	2.1 A
		5V (TPCE280-11R)	5 A
	+12V		0.2 A
	-12V		0.2 A
TPCE280-2xR	3.3V		8 A
	VPWR	12V (TPCE280-20R)	6.25 A
		5V (TPCE280-21R)	8 A
	+12V		0.2 A
	-12V		0.2 A

Table 4-1 : Current Limits for the XMC Modules

*) **System dependent:** After power-up, the PCI-Express specification limits the total power consumption of x8 PCIe Add-In Cards to 25W. If more power is needed, the XMC can request it from the system via mechanisms defined in the PCI-Express specification.

Alternatively, a TPCE280 variant with PCIe Graphics Power Connector could be used.

In principle, an XMC could draw more than 100W. Since most XMCs tend to convert the delivered power into heat, users should keep in mind that it needs appropriate system cooling solutions when such high power XMCs are used.

4.1.3 Stable Power Supply

All power supplies for the XMC slot are stable max. 5ms after the system power supply is stable.

4.2 Installation of an XMC Module

The XMC module has to be mounted on the TPCE280 prior to installation into the system.

Before installing an XMC module, be sure that the power supply for the TPCE280 is turned off.

TPCE280 and XMC are Electrostatic Sensitive Devices (ESD). Use an anti-static mat connected to a wristband when handling or installing the components.

If the XMC has a front panel, first remove the cover from the XMC front panel cut-out of the TPCE280. Install the XMC at an angle so that the XMC front panel pushes through the XMC front panel cut-out. Then rotate down to mate with the XMC connectors on the TPCE280. If the XMC has no front panel, simply plug in the XMC, and leave the cover in the XMC front panel cut-out of the TPCE280.

After the XMC module has been installed, it can be secured on the TPCE280 using the mounting screws that come with the XMC module. There are four screw mounting locations, two at the XMC front panel and two at the standoffs near the XMC bus connectors.

According to the XMC specification, VPWR can be 5V or 12V, and it is up to the XMC to deal with both power supply voltage levels.

Nevertheless, there are some XMCs on the market that work only with VPWR = 5V, sometimes with remarkable and non-reversible effects when they are powered with VPRW = 12V.

For those XMCs, a special TPCE280 variant with VPWR = 5V is available. Always check if your XMC supports the VPWR voltage of the TPCE280 variant used.

For all TPCE280 with VPWR = 12V, this voltage is directly connected to the 12V supply from the PCIe connector. The PCIe specification allows for tolerances of $\pm 8\%$, whereas the XMC specification allows only for $\pm 5\%$. This has to be taken into consideration when using these TPCE280 variants.

5 JTAG

There is one JTAG chain present on the TPCE280. This chain connects the 14-pin JTAG header with the XMC slot. There are no JTAG-capable devices onboard the TPCE280, so the XMC is the only “device” in this chain.

TDI and TDO of the PCIe connector will be interconnected on-board to maintain system board JTAG-Chain integrity.

5.1 USB Type C Connector

The TPCE280 offers an USB Type C Receptacle as an alternative to the 14-pin flat cable header. This USB receptacle is connected to an FTDI FT2232H chip that translates the USB signals to JTAG signals, allowing access to the XMC JTAG chain with a second source programming software and a simple USB cable.

This USB connector is not mounted in any order options by default. Please contact TEWS if you are interested in using it.

5.2 JTAG voltage for XMC Module

The JTAG signaling voltage level on the 14-pin header is always 3.3V.

However, the JTAG voltage that is used for the XMC module, can be setup by a rotary selector switch on the TPCE280; it will be translated to the 3.3V on the JTAG connector.

Position	XMC JTAG Voltage
0	+1.5V
1	+1.8V
2	+2.5V
3	+3.3V

Table 5-1 : Rotary Selector Switch configuration

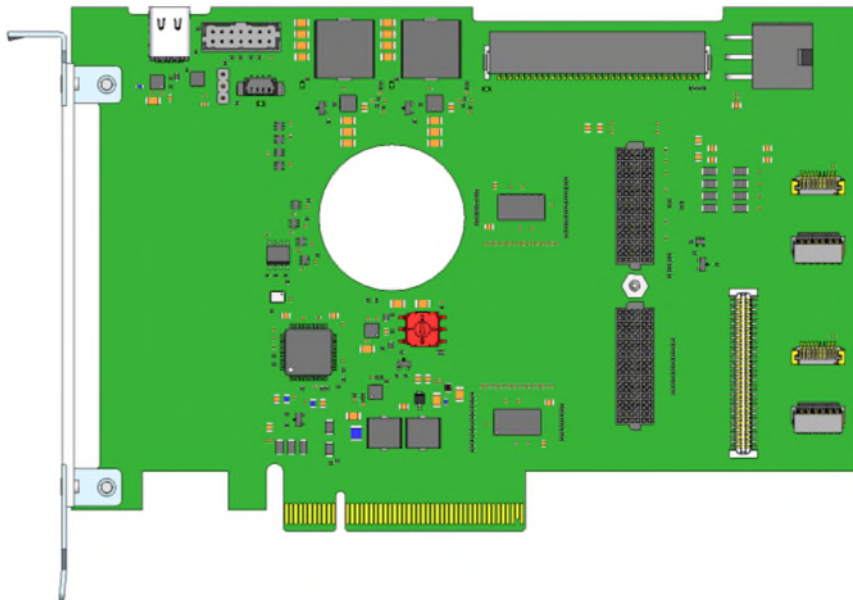

Figure 5-1 : JTAG voltage rotary selector switch location, marked red (Top View of TPCE280)

6 Indicators

6.1 LED Indicators

The TPCE280 provides a couple of board-status LEDs as shown below. All LEDs are labeled on board for better recognition.

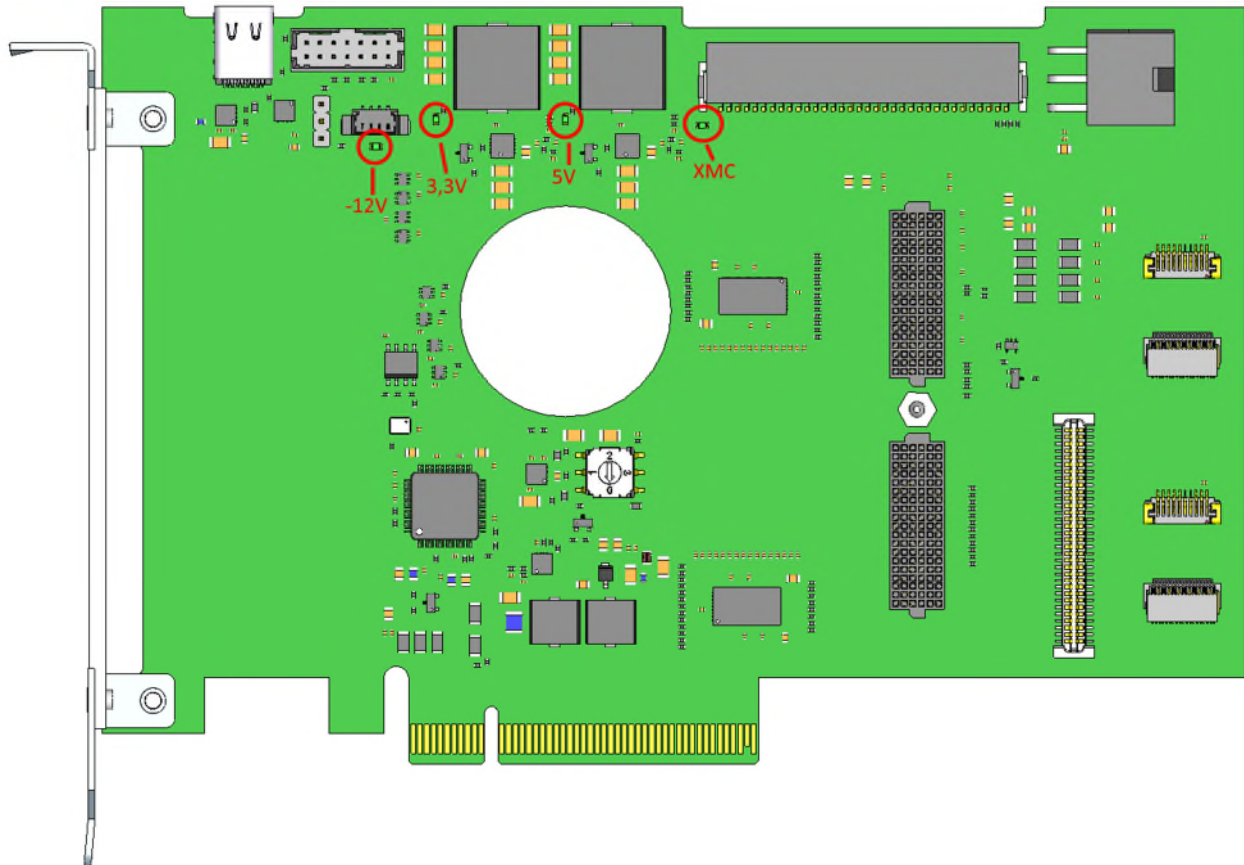

Figure 6-1 : On-board LED Placement

LED		Color	State	Description
+3.3V	3.3V Power Good	Green	Off	3.3V Power Supply is not OK
			On	3.3V Power Supply is OK
+5.0V	5.0V Power Good *)	Green	Off	5.0V Power Supply is not OK
			On	5.0V Power Supply is OK
-12V	-12V Power Good	Green	Off	-12V Power Supply is not OK
			On	-12V Power Supply is OK
XMC	XMC Present LED	Green	Off	No XMC Module detected
			On	XMC Module detected

Table 6-1 : On-board LED Description

*) Only for VPWR = 5V variants

7 Pin Assignments

7.1 XMC J15

	A	B	C	D	E	F
01	PET0p0	PET0n0	3.3V	PET0p1	PET0n1	VPWR
02	GND	GND	TRST ¹⁾	GND	GND	PERST#
03	PET0p2	PET0n2	3.3V	PET0p3	PET0n3	VPWR
04	GND	GND	TCK ¹⁾	GND	GND	
05	PET0p4	PET0n4	3.3V	PET0p5	PET0n5	VPWR
06	GND	GND	TMS ¹⁾	GND	GND	+12V
07	PET0p6	PET0n6	3.3V	PET0p7	PET0n7	VPWR
08	GND	GND	TDI ¹⁾	GND	GND	-12V
09						VPWR
10	GND	GND	TDO ¹⁾	GND	GND	GA0
11	PER0p0	PER0n0		PER0p1	PER0n1	VPWR
12	GND	GND	GA1	GND	GND	
13	PER0p2	PER0n2	3.3V_AUX ²⁾	PER0p3	PER0n3	VPWR
14	GND	GND	GA2	GND	GND	SMCLK ⁶⁾
15	PER0p4	PER0n4		PER0p5	PER0n5	VPWR
16	GND	GND	MVMRO ³⁾	GND	GND	SMDAT ⁶⁾
17	PER0p6	PER0n6		PER0p7	PER0n7	
18	GND	GND		GND	GND	
19	REFCLK+0	REFCLK-0		WAKE# ⁴⁾	ROOT0# ⁵⁾	

Table 7-1 : XMC J15 Pin Assignment

Notes:

- 1) JTAG lines are routed to a 14pin header on-board, not to the PCIe edge card connector
- 2) 3.3V_AUX is connected to the PCIe edge card connector, so it is up to the mainboard to deliver this power supply. If a different configuration is needed, please contact TEWS.
- 3) MVMRO is set to logic high by default, prohibiting write access. If a different configuration is needed, please contact TEWS.
- 4) WAKE# is connected to the PCIe edge card connector, so it is up to the mainboard to provide for this signal. If a different configuration is needed, please contact TEWS.
- 5) ROOT# is not supported; this pin is not connected on the TPCE280 by default. If a different configuration is needed, please contact TEWS.
- 6) SMCLK and SMDAT are not connected to the PCIe edge card connector by default. If a different configuration is needed, please contact TEWS.

7.2 XMC J16 I/O Connector

For J16 MGT Back I/O access, two Samtec Firefly Micro Flyover Connectors are used. These consist of two parts each. One part is the connector for the high speed signals (UEC5) and the second part (UCC8) is for power and control signals.

7.2.1 X5 – Firefly Micro Flyover Connector #1

7.2.1.1 UEC5

Pin-Count	38
Connector Type	Firefly Micro Flyover Connector
Source & Order Info	Samtec – UEC5-019-1-H-D-RA-2-A

J16 Pin	X5 UEC5 – A Signal Name	UEC A/B Pin	X5 UEC5 – B Signal Name	J16 Pin
	GND	1	GND	
B1	Tx0-	2	Tx1-	E1
A1	TX0+	3	Tx1+	D1
	GND	5	GND	
B3	Tx2-	5	Tx3-	E3
A3	Tx2+	6	Tx3+	D3
	GND	7	GND	
C18	DIG_IO_00-	8	DIG_IO_01-	F18
C19	DIG_IO_00+	9	DIG_IO_01+	F19
	GND	10	GND	
C17	DIG_IO_02+	11	DIG_IO_03+	F17
C16	DIG_IO_02-	12	DIG_IO_03-	F16
	GND	13	GND	
D13	Rx3+	14	Rx2+	A13
E13	Rx3-	15	Rx2-	B13
	GND	16	GND	
D11	Rx1+	17	Rx0+	A11
E11	Rx1-	18	Rx0-	B11
	GND	19	GND	

Table 7-2 : Pin Assignment X5 UEC5

7.2.1.2 UCC8

Pin-Count	10
Connector Type	Firefly Micro Flyover Connector
Source & Order Info	Samtec – UCC8-010-1-H-S-2-A

X5 Pin	Signal Name	J16 Pin
1	+3.3V	-
2	GND	-
3	PRESENTL	F4
4	SELECTL	F5
5	INTL	F6
6	RESETL	F7
7	SDA	F8
8	SCL	F9
9	n.c.	-
10	+3.3V	-

Table 7-3 : Pin Assignment X5 UCC8

7.2.2 X6 – Firefly Micro Flyover Connector #2

7.2.2.1 UEC5

Pin-Count	38
Connector Type	Firefly Micro Flyover Connector
Source & Order Info	Samtec – UEC5-019-1-H-D-RA-2-A

J16 Pin	X6 UEC5 – A Signal Name	UEC A/B Pin	X6 UEC5 – B Signal Name	J16 Pin
	GND	1	GND	
B5	Tx4-	2	Tx5-	E5
A5	TX4+	3	Tx5+	D5
	GND	5	GND	
B7	Tx6-	5	Tx7-	E7
A7	Tx6+	6	Tx7+	D7
	GND	7	GND	
C14	DIG_IO_04-	8	DIG_IO_05-	F14
C15	DIG_IO_04+	9	DIG_IO_05+	F15
	GND	10	GND	
C13	DIG_IO_06+	11	DIG_IO_07+	F13
C12	DIG_IO_06-	12	DIG_IO_07-	F12
	GND	13	GND	
D17	Rx7+	14	Rx6+	A17
E17	Rx7-	15	Rx6-	B17
	GND	16	GND	
D15	Rx5+	17	Rx4+	A15
E15	Rx5-	18	Rx4-	B15
	GND	19	GND	

Table 7-4 : Pin Assignment X6 UEC5

7.2.2.2 UCC8

Pin-Count	10
Connector Type	Firefly Micro Flyover Connector
Source & Order Info	Samtec – UCC8-010-1-H-S-2-A

X6 Pin	Signal Name	J16 Pin
1	+3.3V	-
2	GND	-
3	PRESENTL	C4
4	SELECTL	C5
5	INTL	C6
6	RESETL	C7
7	SDA	C8
8	SCL	C9
9	n.c.	-
10	+3.3V	-

Table 7-5 : Pin Assignment X6 UCC8

7.3 XMC J14 I/O Connector

Pin Count	68
Connector Type	ERNI SMC, right angle male, 1.27mm pitch
Source & Order Info	ERNI 154766

Signal	J14 Pin	ERNI Pin	Connector view	ERNI Pin	J14 Pin	Signal
I/O 2 (I/O00-)	2	b1		a1	1	I/O 1 (I/O00+)
I/O 4 (I/O01-)	4	b2		a2	3	I/O 3 (I/O01+)
I/O 6 (I/O02-)	6	b3		a3	5	I/O 5 (I/O02+)
I/O 8 (I/O03-)	8	b4		a4	7	I/O 7 (I/O03+)
I/O 10 (I/O04-)	10	b5		a5	9	I/O 9 (I/O04+)
I/O 12 (I/O05-)	12	b6		a6	11	I/O 11 (I/O05+)
I/O 14 (I/O06-)	14	b7		a7	13	I/O 13 (I/O06+)
I/O 16 (I/O07-)	16	b8		a8	15	I/O 15 (I/O07+)
I/O 18 (I/O08-)	18	b9		a9	17	I/O 17 (I/O08+)
I/O 20 (I/O09-)	20	b10		a10	19	I/O 19 (I/O09+)
I/O 22 (I/O10-)	22	b11		a11	21	I/O 21 (I/O10+)
I/O 24 (I/O11-)	24	b12		a12	23	I/O 23 (I/O11+)
I/O 26 (I/O12-)	26	b13		a13	25	I/O 25 (I/O12+)
I/O 28 (I/O13-)	28	b14		a14	27	I/O 27 (I/O13+)
I/O 30 (I/O14-)	30	b15		a15	29	I/O 29 (I/O14+)
I/O 32 (I/O15-)	32	b16		a16	31	I/O 31 (I/O15+)
I/O 34 (I/O16-)	34	b17		a17	33	I/O 33 (I/O16+)
I/O 36 (I/O17-)	36	b18		a18	35	I/O 35 (I/O17+)
I/O 38 (I/O18-)	38	b19		a19	37	I/O 37 (I/O18+)
I/O 40 (I/O19-)	40	b20		a20	39	I/O 39 (I/O19+)
I/O 42 (I/O20-)	42	b21		a21	41	I/O 41 (I/O20+)
I/O 44 (I/O21-)	44	b22		a22	43	I/O 43 (I/O21+)
I/O 46 (I/O22-)	46	b23		a23	45	I/O 45 (I/O22+)
I/O 48 (I/O23-)	48	b24		a24	47	I/O 47 (I/O23+)
I/O 50 (I/O24-)	50	b25		a25	49	I/O 49 (I/O24+)
I/O 52 (I/O25-)	52	b26		a26	51	I/O 51 (I/O25+)
I/O 54 (I/O26-)	54	b27		a27	53	I/O 53 (I/O26+)
I/O 56 (I/O27-)	56	b28		a28	55	I/O 55 (I/O27+)
I/O 58 (I/O28-)	58	b29		a29	57	I/O 57 (I/O28+)
I/O 60 (I/O29-)	60	b30		a30	59	I/O 59 (I/O29+)
I/O 62 (I/O30-)	62	b31		a31	61	I/O 61 (I/O30+)
I/O 64 (I/O31-)	64	b32		a32	63	I/O 63 (I/O31+)
GND	-	b33		a33	-	GND
GND	-	b34		a34	-	GND

Table 7-6 : X4 - J14 I/O Pin Assignment

All +/- pairs are routed differential, impedance controlled and equal-lengthed.

7.4 X8 - 14-Pin JTAG Header

The following JTAG connector with the below mentioned pin mapping is provided.

Pin-Count	14
Connector Type	14-position 2mm flat cable header. Compatible with XILINX USB programmer flat cable.
Source & Order Info	Molex 87832-142 (180°)

Pin Assignment				
Description	Pin	Connector View	Pin	Description
NC	1		2	VREF
GND	3		4	TMS
GND	5		6	TCK
GND	7		8	TDO
GND	9		10	TDI
GND	11		12	NC
HDR_EN# *)	13		14	NC

Table 7-7 : X5 – 14-pin JTAG Header Pin Assignment

*) The JTAG cable has to connect this pin to GND

7.5 X3 – PCIe VGA Graphics Power Connector

The TPCE280-2x variants provide an additional PCIe VGA Graphics Power Connector for increased power requirements.

Pin-Count	6
Connector Type	6-position (2x3) PCI Express auxiliary power connector Mini-Fit Jr. Power Connector
Source & Order Info	Molex 45732-0001

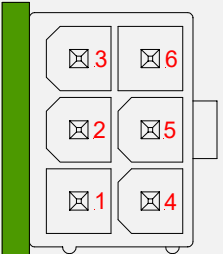
Pin Assignment				
Description	Pin	Connector View	Pin	Description
+12V	3		6	GND
+12V	2		5	GND *)
+12V	1		4	GND

Table 7-8 : X3 – 6-pin Auxilliary Power Connector

*) The TPCE280 connects this pin to GND and does not do any power supply detection with this pin.