

TPMC160 Automotive Sensor Simulator

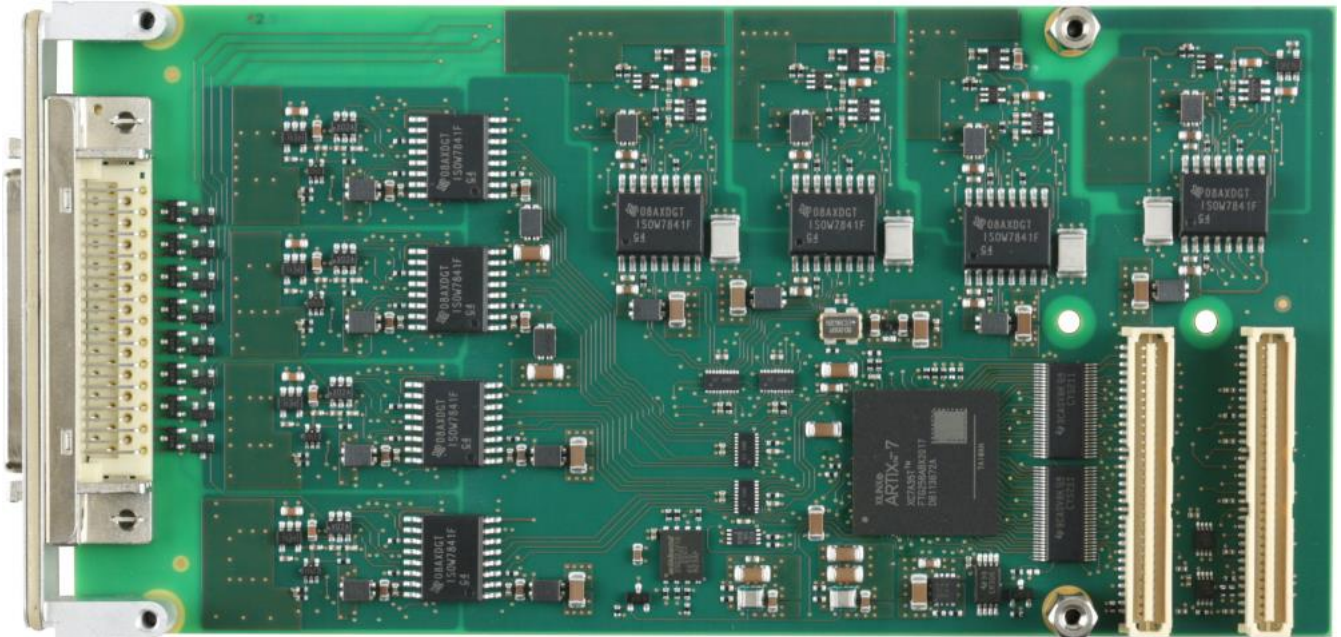

TPMC160-10R

Application Information

The TPMC160 is a standard single-width 32 bit PMC module and supports a 33 MHz / 32-bit universal (5 V / 3.3 V) PCI interface.

The TPMC160 offers eight isolated automotive sensor simulator channels, which can act as a PSI5 or as wheel speed sensor. The sensor simulation supports a current sink with three adjustable levels. It also features PSI5 Sync and Reset pulse detection. The sensor simulation channels are isolated against the system and against each other.

PSI5 support includes PSI5-P, -U and -D bus topologies and both 125 kbps and 189 kbps transmission rates.

Asynchronous and Variable Time Triggered Synchronous Operation Modes are supported.

Wheel speed sensor support covers two- and three current levels sensors, sensors with additional status information and the "AK-protocol".

All TPMC160 signals are accessible through a HD50 SCSI-2 type front I/O connector.

Software Support (TPMC160-SW-xx) for different operating systems is available.

Technical Information

- Standard single-width 32 bit PMC module conforming to IEEE P1386.1
 - Board size: 149 mm x 74 mm
 - PCI 3.0 compliant interface
 - 5 V and 3.3 V PCI /O signaling interface
- HD50 SCSI type I/O connector mounted in front panel
- 8 channels, configurable as PSI5 or Wheel Speed Sensor simulation
- PSI5 supports -P/-U/-D/-A/-V communication modes, 125 and 189 kbps transmission rates
- Wheel speed sensor supports 2- and 3-level sensors and VDA/AK-Protocol
- Current sinks with three adjustable levels
- Custom protocol option available
- Operating temperature -40°C to +85°C
- MTBF (MIL-HDBK217F/FN2 G_B 20°C) TPMC160-10R: 369000 h

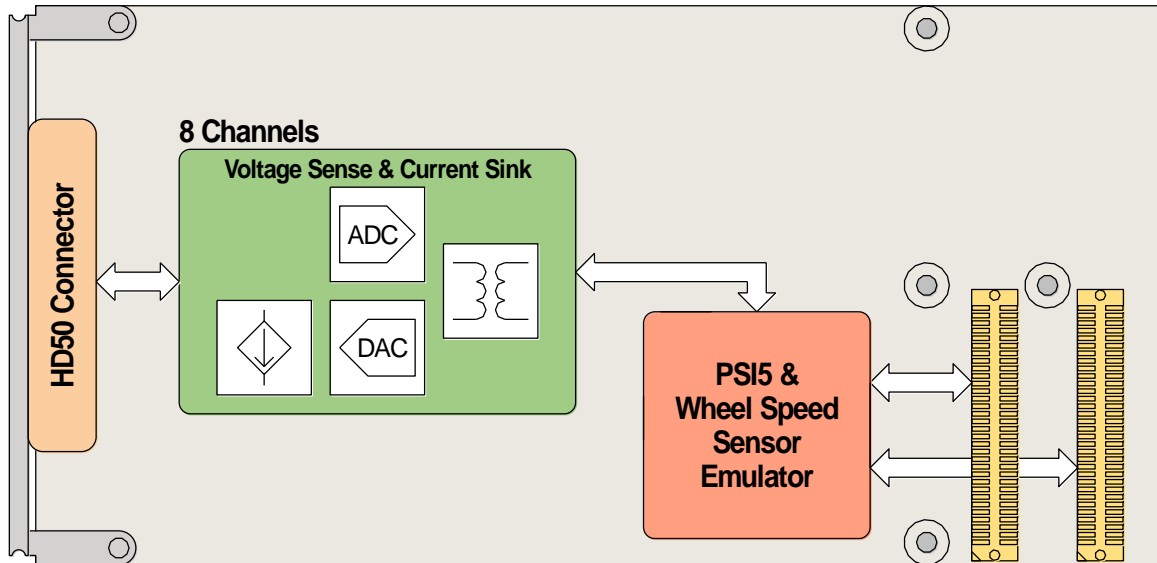

Order Information

RoHS Compliant

TPMC160-10R Automotive Sensor Simulator

For the availability of non-RoHS compliant (lead solder) products please contact TEWS.

Documentation

TPMC160-DOC User Manual

Software

TPMC160-SW-25 Integrity Software Support

TPMC160-SW-42 VxWorks Software Support (Legacy and VxBus-Enabled Software Support)

TPMC160-SW-65 Windows Software Support

TPMC160-SW-82 Linux Software Support

TPMC160-SW-95 QNX Software Support

For other operating systems please contact TEWS.

Related Products

TA301 Cable Kit for modules with HD50 male connector