

TPMC363 Conduction Cooled PMC 4 Channel High Speed Synch/Asynch Serial Interface

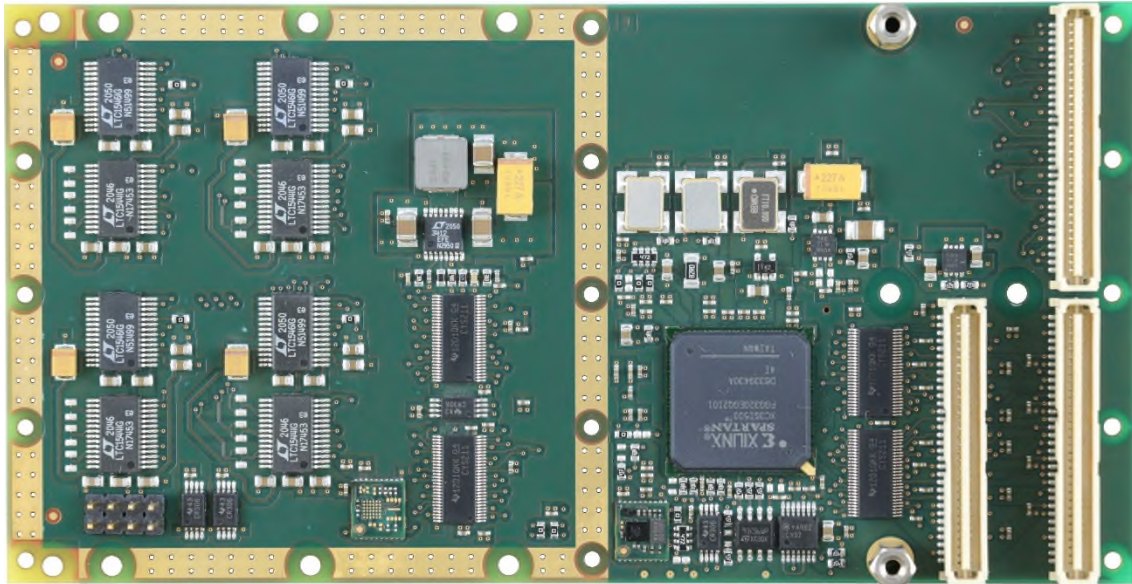

TPMC363-10R

Application Information

The TPMC363 is a conduction cooled single-width 32 bit PMC with four high speed serial data communication channels.

The TPMC363 is the successor of the discontinued TPMC362, providing similar functionality and full connector and pin-out compatibility.

The serial communication controller is implemented in FPGA logic, along with the bus master capable PCI interface, guaranteeing long term availability and having the option to implement additional functions in the future.

Each channel provides dedicated receive and transmit FIFOs for high data throughput.

Data transfer on the PCI bus is handled via TPMC363 initiated DMA cycles with minimum host/CPU intervention.

Several serial communication protocols are supported by each channel, such as asynchronous, isochronous, synchronous and HDLC mode.

A 14.7456 MHz oscillator provides standard asynchronous baud rates. An additional 24 MHz oscillator is provided for other baud rates. A 10 MHz oscillator is used for the synchronous baud rate of 10 Mbit/s.

Each channel also provides various interrupt sources, generated on INTA. The interrupt sources can be enabled or disabled individually.

Multiprotocol transceivers are used for the line interface. The physical interface is selectable by software, individually for each channel as EIA-232, EIA-422, EIA-449, EIA-530, EIA-530A, V.35, V.36 or X.21.

The following signals are provided by the TPMC363 for each channel at the front and rear I/O connectors: Receive Data (RxD +/-), Transmit Data (TxD +/-), Receive Clock (RxC +/-), Transmit Clock (TxC +/-), Ready-To-Send (RTS +/-), Clear-To-Send (CTS +/-), Carrier-Detect (CD +/-) and GND.

The TPMC363 provides rear panel I/O via P14.

Software Support (TDRV009-SW-xx) for different operating systems is available.

Technical Information

- Conduction Cooled single-width 32 bit PMC module conforming to IEEE P1386.1
- PCI 2.1 compliant master/slave interface
- 3.3V and 5V PCI Signaling Voltage
- Board size: 143.75 mm x 74 mm
- Four high speed asynchronous/synchronous (HDLC) serial interfaces
- Support of Rx/D, Tx/D, Rx/C, Tx/C, RTS, CTS, CD and GND on rear connector P14
- Physical interface (individually programmable per channel):
EIA-232, EIA-422, EIA-449, EIA-530, EIA-530A, V.35, V.36 and X.21
- Maximum data rate: 10 Mbit/s (synchronous), 2 Mbit/s (asynchronous), internally or externally provided clock
- EIA-232: up to 115.2 kbit/s
Temperature range: -40°C to +85°C

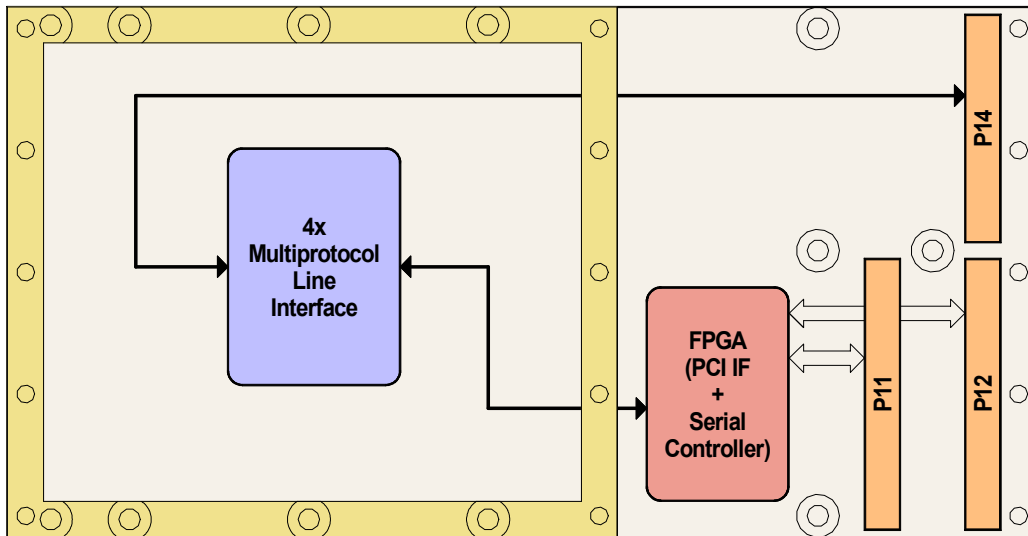

Block Diagram

Order Information

RoHS Compliant

TPMC363-10R ccPMC, 4 Channel High Speed Synch/Asynch Serial Interface, P14 I/O

For the availability of non-RoHS compliant (lead solder) products please contact TEWS.

Documentation

TPMC363-DOC User Manual

Software

- TDRV009-SW-25** Integrity Software Support
- TDRV009-SW-42** VxWorks Software Support (Legacy and VxBus-Enabled Software Support)
- TDRV009-SW-65** Windows Software Support
- TDRV009-SW-82** Linux Software Support
- TDRV009-SW-95** QNX Software Support

For other operating systems please contact TEWS.

Related Products

TPIM005 PIM I/O Module, HD68 connector, for TPMC863/TPMC363

TEWS TECHNOLOGIES GmbH keeps the right to change technical specification without further notice.
All trademarks mentioned are property of their respective owners.

Issue 1.3.3
2022-01-12

TEWS TECHNOLOGIES GmbH

Am Bahnhof 7 25469 Halstenbek, Germany
Phone: +49 (0) 4101 4058 0 Fax: +49 (0) 4101 4058 19
e-mail: info@tews.com www.tews.com