

# TPMC883

## 10/100/1000 Mbit/s Ethernet Adapter

Version 1.0

Revision A

## User Manual

Issue 1.1

September 2006

D76883800

---

**TEWS TECHNOLOGIES GmbH**

Am Bahnhof 7  
25469 Halstenbek, Germany  
[www.tews.com](http://www.tews.com)

Phone: +49-(0)4101-4058-0  
Fax: +49-(0)4101-4058-19  
e-mail: [info@tews.com](mailto:info@tews.com)

**TEWS TECHNOLOGIES LLC**

9190 Double Diamond Parkway,  
Suite 127, Reno, NV 89521, USA  
[www.tews.com](http://www.tews.com)

Phone: +1 (775) 850 5830  
Fax: +1 (775) 201 0347  
e-mail: [usasales@tews.com](mailto:usasales@tews.com)

**TPMC883-10**

10/100/1000 Mbit/s Ethernet Adapter  
Front panel connector

This document contains information, which is proprietary to TEWS TECHNOLOGIES GmbH. Any reproduction without written permission is forbidden.

TEWS TECHNOLOGIES GmbH has made any effort to ensure that this manual is accurate and complete. However TEWS TECHNOLOGIES GmbH reserves the right to change the product described in this document at any time without notice.

TEWS TECHNOLOGIES GmbH is not liable for any damage arising out of the application or use of the device described herein.

**Style Conventions**

Hexadecimal characters are specified with prefix 0x, i.e. 0x029E (that means hexadecimal value 029E).

For signals on hardware products, an 'Active Low' is represented by the signal name with # following, i.e. IP\_RESET#.

Access terms are described as:

W	Write Only
R	Read Only
R/W	Read/Write
R/C	Read/Clear
R/S	Read/Set

©2005-2006 by TEWS TECHNOLOGIES GmbH

---

<b>Issue</b>	<b>Description</b>	<b>Date</b>
1.0	First Issue	June 2005
1.1	New address TEWS LLC	September 2006

---

## Table of Contents

<b>1</b>	<b>PRODUCT DESCRIPTION</b> .....	<b>6</b>
<b>2</b>	<b>TECHNICAL SPECIFICATION</b> .....	<b>7</b>
<b>3</b>	<b>82545 GIGABIT ETHERNET CONTROLLER</b> .....	<b>8</b>
	3.1 82545 PCI Header .....	8
	3.2 Configuration EEPROM.....	9
<b>4</b>	<b>PIN ASSIGNMENT – I/O CONNECTOR</b> .....	<b>10</b>
	4.1 Front Panel I/O Connector .....	10
	4.2 Front Panel LED Indicators.....	10

---

## Table of Figures

FIGURE 1-1 : BLOCK DIAGRAM.....	6
FIGURE 2-1 : TECHNICAL SPECIFICATION.....	7
FIGURE 3-1 : 82545 PCI HEADER.....	8
FIGURE 3-2 : 82545 CONFIGURATION EEPROM SETTINGS.....	9
FIGURE 4-1 : FRONT I/O PIN ASSIGNMENT.....	10
FIGURE 4-2 : LED STATUS DEFINITIONS.....	10

# 1 Product Description

The TPMC883 is a PCI Mezzanine Card (PMC) compatible module providing a single channel Gigabit Ethernet 10 / 100 / 1000BASE-TX interface.

For highest data rates, the TPMC883 has a 64 bit, 133/100/66 MHz PCI bus interface and is capable of full speed bus-master DMA operations utilizing maximum PCI bandwidth.

An Intel™ 82545EM Ethernet Controller is used, which supports 10, 100 and 1000 Mbit/s transmission rates for half and full duplex operation. The TPMC883 is capable of performing an auto negotiation algorithm which allows both link-partners to find out the best link-parameters by themselves. The TPMC883 is widely user configurable via configuration and status register access over the PCI bus. Front panel mounted LEDs indicate various network activities.

The TPMC883-10 provides a 10/100/1000 Mbit/s network connection via a front panel RJ45 connector. The port is galvanically isolated from the Ethernet Controller.

The operating temperature range is 0°C to +70°C.

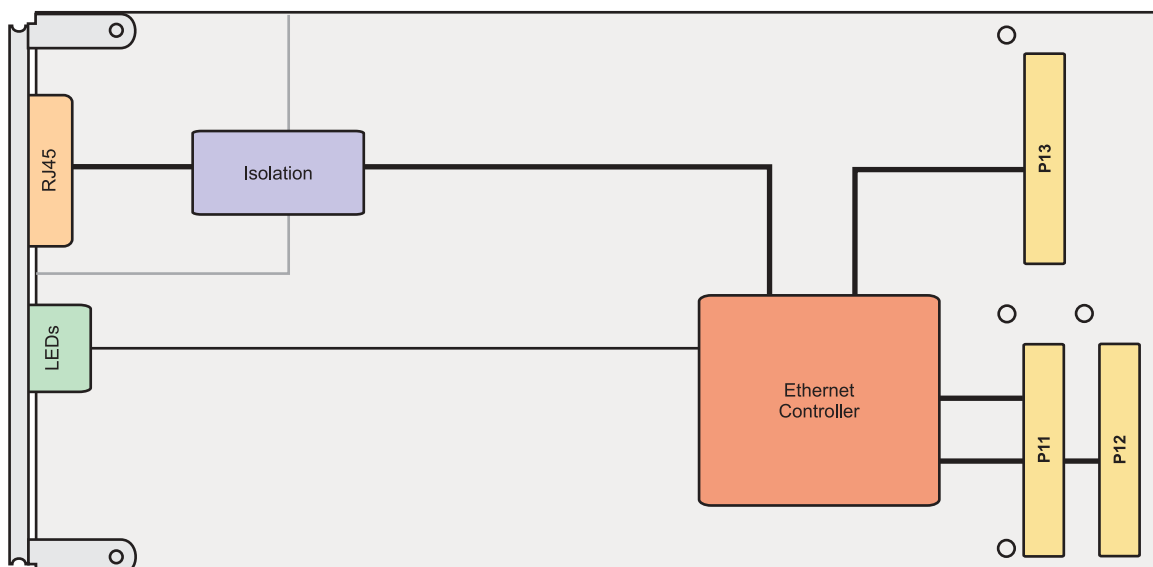

Figure 1-1 : Block Diagram

## 2 Technical Specification

<b>PMC Interface</b>	
<b>Mechanical Interface</b>	PCI Mezzanine Card (PMC) Interface Single Size
<b>Electrical Interface</b>	PCI 2.2 (64 bit / 66 MHz) and PCI-X 1.0a (64 bit / 133 MHz) compliant interface 3.3V and 5V PCI Signaling Voltage
<b>On Board Devices</b>	
<b>Ethernet Controller with Integrated PCI and Physical Interface</b>	82545EM (Intel)
<b>Ethernet Interface</b>	
<b>Number of Channels</b>	1
<b>FIFO</b>	64 Kbyte Transmit and Receive FIFOs
<b>Interrupts</b>	Using PCI INTA
<b>I/O Connector</b>	Front panel Modular Jack
<b>Physical Data</b>	
<b>Power Requirements</b>	1000 mA typical @ +3.3V DC
<b>Temperature Range</b>	Operating    0 °C to 70 °C Storage      -40°C to +70°C
<b>MTBF</b>	418000 h
<b>Humidity</b>	5 – 95 % non-condensing
<b>Weight</b>	65 g

Figure 2-1 : Technical Specification

# 3 82545 Gigabit Ethernet Controller

## 3.1 82545 PCI Header

Offset	PCI Configuration Register				Setting
	31 - 24	23 - 16	15 - 08	07 - 00	
0x00	Device ID		Vendor ID		0x100F_8086
0x04	Status		Command		0x0230_0007
0x08	Class Code			Revision ID	0x0200_00xx
0x0C	BIST	Header	Latency	Cache Line	0x0000_xx00
0x10	PCI Base Address 0 (Memory Mapped Configuration Register)				0xFFFE_0000 (128 Kbyte)
0x14	PCI Base Address 2 (Memory Mapped FLASH Space)				0xFFFF_0000 (64 Kbyte)
0x18	PCI Base Address 1 (I/O Mapped Configuration Register)				0xFFFF_FFF9 (8 Byte)
0x1C	Reserved				0x0000_0000
0x20	Reserved				0x0000_0000
0x24	Reserved				0x0000_0000
0x28	Reserved				0x0000_0000
0x2C	Subsystem ID		Subsystem Vendor ID		0x0373_1498
0x30	Expansion ROM PCI Base Address				0x0000_0000
0x34	Reserved			Cap. Pointer	0x0000_00DC
0x38	Reserved				0x0000_0000
0x3C	Max_Lat	Min_Gnt	Interrupt Pin	Interrupt Line	0x00FF_0100
0xDC	Power Management Cap.		Next Cap.	Cap. ID	0x7E22_0001
0xE0	Reserved	Data	Power Management CSR		0x4B00_4000

Figure 3-1 : 82545 PCI Header



## 3.2 Configuration EEPROM

After power-on or PCI reset the 82545 loads the initial configuration register data from the on board configuration EEPROM.

See the 82545 Manual for more information.

EEPROM Address	Offset							
	0x00	0x02	0x04	0x06	0x08	0x0A	0x0C	0x0E
0x00	0xYYYY	0xYYYY	0xYYYY	0x0420	0xFFFF	0xFFFF	0xFFFF	0xFFFF
0x10	0x0000	0x0000	0x4406	0x0373	0x1498	0x0373	0x1498	0x30E8
0x20	0x0000	0x0373	0x0000	0x0000	0x38C8	0xFFFF	0xFFFF	0xFFFF
0x30	0xFFFF	0xFFFF	0xFFFF	0xFFFF	0xFFFF	0xFFFF	0xFFFF	0xFFFF
0x40	0x0000	0x7863	0x0000	0x0000	0x28C8	0xFFFF	0xFFFF	0xFFFF
0x50	0xFFFF	0xFFFF	0xFFFF	0xFFFF	0xFFFF	0xFFFF	0xFFFF	0x0602
0x60	0x90EC	0x0000	0x0000	0x0001	0x90EC	0x0000	0x0000	0x0000
0x70	0x0000	0x0000	0x0000	0x0000	0x0000	0x0000	0x0000	0xZZZZ

Figure 3-2 : 82545 Configuration EEPROM Settings

YYYY = Individual Ethernet Address

ZZZZ = EEPROM Checksum

## **4 Pin Assignment – I/O Connector**

### **4.1 Front Panel I/O Connector**

Pin	Signal
1	TX0/RX0+
2	TX0/RX0-
3	TX1/RX1+
4	TX2/RX2+
5	TX2/RX2-
6	TX1/RX1-
7	TX3/RX3+
8	TX3/RX3-

Figure 4-1 : Front I/O Pin Assignment

### **4.2 Front Panel LED Indicators**

The Ethernet Channel provides 4 LED indicators: 100, 1000, LINK and ACT. See table below for detail:

Name	Description
100	Indicates 100BaseT Speed when LED is on
1000	Indicates 1000BaseT Speed when LED is on
LINK	Indicates Link established when Led is on
ACT	Indicates Activity when LED is on

Figure 4-2 : LED Status Definitions

When both Speed LEDs are off, then a 10BaseT Speed connection is established.