

## TQMC700 Reconfigurable AMD Artix™ 7 FPGA (XC7A50T) 16 TTL I/O, 8 AD, 8 DA, single-width QMC

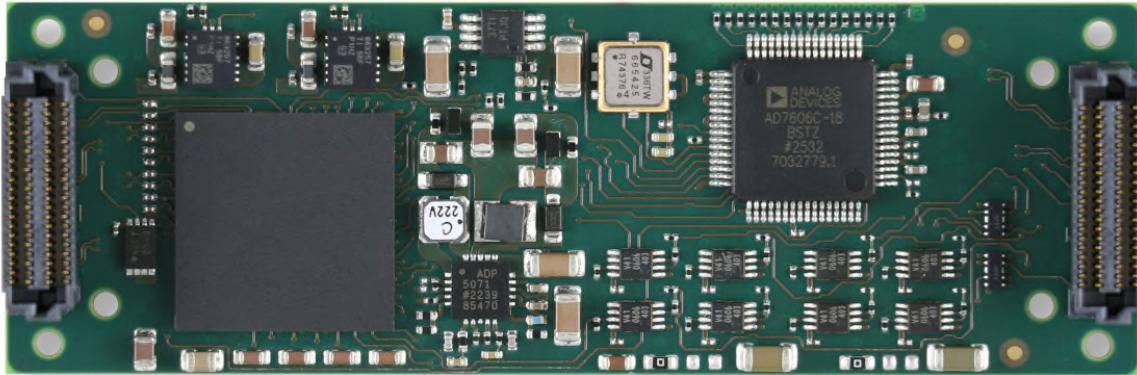

TQMC700-10R

### Application Information

The TQMC700 is a VITA 93.0 compatible single-width QMC offering a user programmable FPGA AMD Artix™ 7 XC7A50T.

The TQMC700 provides 16 ESD-protected 5V-tolerant TTL lines. All I/O lines are individually programmable as input or output. TTL I/O lines can be set to high, low, or tristate.

The 18 bit ADC offers 8 input channels, each of them has a sampling rate of up to 1 Msps. Each channel can be operated in bipolar single-ended, unipolar single-ended and bipolar differential mode. In the single-ended modes it offers software selectable input voltage ranges of 0-5 V, 0-10 V, 0-12.5 V,  $\pm 2.5$  V,  $\pm 5$  V,  $\pm 6.25$  V,  $\pm 10$  V and  $\pm 12.5$  V. In differential mode the input voltages are selectable between  $\pm 5$  V,  $\pm 10$  V,  $\pm 12.5$  V and  $\pm 20$  V. There is a flexible digital filter offering a oversampling ratio up to 256.

The DACs offer 8 channels of 16 bit analog outputs with software selectable output voltage ranges of 0-5 V, 0-10 V, 0-10.8 V,  $\pm 5$  V,  $\pm 10$  V or  $\pm 10.8$  V. The output voltage range can be individually set per channel. The conversion time is typ. 10  $\mu$ s and the DAC outputs are capable to drive a load of 2 k $\Omega$ , with a capacitance up to 4000 pF.

Factory determined A/D and D/A correction data is stored in an EEPROM unique to each individual TQMC700.

The User FPGA is configured by a SPI flash. An in-circuit debugging option is available via the QMC's JTAG interface for read back and real-time debugging of the FPGA design (using the AMD Vivado™ ILA).

User applications for the TQMC700 can be developed using the AMD design tools, which can be downloaded free of charge from [www.amd.com](http://www.amd.com).

TEWS offers a well-documented Board Reference Design (BRD) that illustrates how to make use of the TQMC700 main functionalities. It implements a PCIe interface including register mapping and basic I/O. It comes as a Vivado Design Suite project with source code and as a ready-to-download bit stream.

The TQMC700 is available as air cooled and conduction cooled variant.



Conduction Cooled QMC

### Technical Information

- Form Factor: Standard single QMC conforming to VITA 93.0
  - Board size: 78.25 mm x 26 mm
- PCI Express 2.1 compliant interface
- Artix 7 User programmable FPGA
  - XC7A50T-2
  - PCIe endpoint in FPGA
- 128 Mbit SPI-EEPROM for FPGA configuration and User Data
- 8 channels 18 bit analog input
  - Simultaneous sampling
  - differential or single-ended inputs
  - Programmable input voltage (one setting for all channels):  
0-5 V, 0-10 V, 0-12.5 V, ±2.5 V, ±5 V, ±6.25 V, ±10 V, ±12.5 V
- Digital I/O
  - 16 ESD-protected 5 V-tolerant TTL lines
  - Direction individually programmable
  - Sampling rate: 1 Msps
  - Overvoltage protection
- 8 channels single-ended 16 bit analog output
  - Simultaneous update
  - Programmable output voltage:  
0-5 V, 0-10 V, 0-10.8 V, ±5 V, ±10 V, ±10.8 V
  - Conversion time: typ. 10 μs
  - Up to 2 kΩ resistive, 4000 pF capacitive load
  - Overcurrent protection
- Factory determined A/D and D/A correction data
- Operating temperature -40 °C to +85 °C

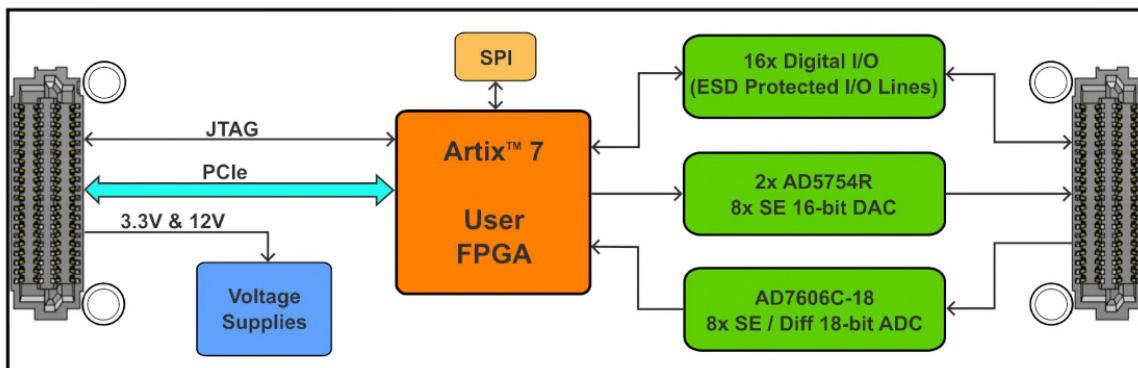

Block Diagram

### Order Information

#### RoHS Compliant

**TQMC700-10R-A** 16 TTL I/O, 8 AD, 8 DA, Artix 7 XC7A50T FPGA, air cooled

**TQMC700-10R-H** 16 TTL I/O, 8 AD, 8 DA, Artix 7 XC7A50T FPGA, conduction cooled

For the availability of non-RoHS compliant (lead solder) products please contact TEWS.

For the availability of conformal coated products please contact TEWS.

#### Software

**TDRV020-SW-25** Integrity Software Support

**TDRV020-SW-42** VxWorks Software Support

**TDRV020-SW-65** Windows Software Support

**TDRV020-SW-82** Linux Software Support

**TDRV020-SW-95** QNX Software Support

For other operating systems please contact TEWS.