

## TQMC701 8 Single-Ended / Differential A/D Channels, 8 D/A Channels and 16 Digital I/O Channels

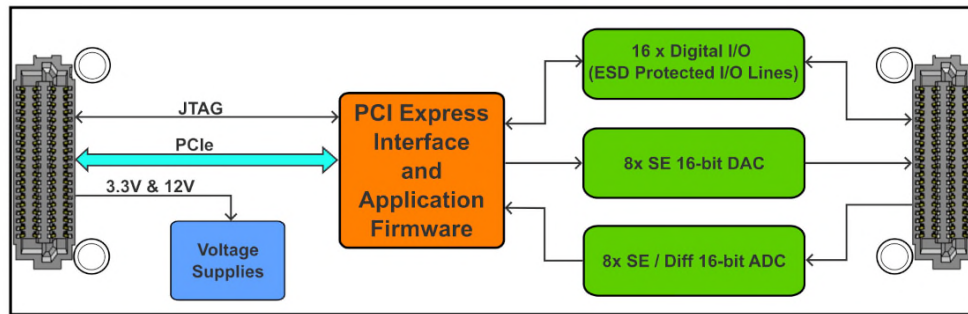

TQMC701 Block Diagram

### Application Information

The TQMC701 is a VITA 93.0 compatible single-width QMC providing 8 channels of simultaneous sampling single ended or true differential bipolar analog inputs, 8 channels of simultaneous update analog voltage output and 16 ESD-protected 5 V tolerant TTL digital I/O lines.

The 16 bit analog input channels support per channel software configurable input modes and voltage ranges. Each channel can be operated in bipolar single-ended, unipolar single-ended and bipolar differential mode. In the single-ended modes it offers software selectable input voltage ranges of 0-5 V, 0-10 V, 0-12.5 V,  $\pm 2.5$  V,  $\pm 5$  V,  $\pm 6.25$  V,  $\pm 10$  V and  $\pm 12.5$  V. In differential mode the input voltage ranges are selectable between  $\pm 5$  V,  $\pm 10$  V,  $\pm 12.5$  V and  $\pm 20$  V. Sampling rate for all channels active is up to 1 Msps.

The 16 bit analog output channels support per channel software configurable output voltage ranges of 0-5 V, 0-10 V, 0-10.8 V,  $\pm 5$  V,  $\pm 10$  V or  $\pm 10.8$  V. The conversion time is typ. 10  $\mu$ s and the DAC outputs are capable to drive a load of 2 k $\Omega$ , with a capacitance of up to 4000 pF.

All 16 digital I/O lines are ESD-protected and 5 V-tolerant. Every I/O line is individually programmable as input or output if not used for external synchronization. TTL I/O lines can be set to high, low, or tristate.

Factory determined A/D and D/A correction data is stored in an EEPROM unique to each individual TQMC701. The correction data can be used to perform a hardware correction for each A/D and D/A channel during functional operation.

The TQMC701 provides different operation modes to perform manual and automatic A/D and D/A conversions.

For automatic conversions there are dedicated A/D and D/A sequencer units. These include on-board data buffer and DMA controller for A/D data transfer, D/A data fetch and conversion rate generators.

Sequencers provide optionally a Frame Mode for repetitive frames of A/D and D/A conversions upon an internal or external trigger signal event.

Conversion clock (conversion rate) and frame trigger signals may be generated on-board for internal use. Optionally these can be provided via the I/O connector if the card is operating as a master card in a Multi-Board configuration (externally synchronization). The conversion clock (conversion rate) and frame trigger signals may also be sourced externally.

The TQMC701 is available as air cooled and conduction cooled variant.

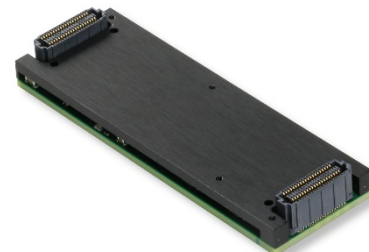

Conduction Cooled QMC

### Technical Information

- Form Factor: Standard single QMC conforming to VITA 93.0
  - Board size: 78.25 mm x 26 mm
- PCI Express 2.1 compliant interface
- FPGA based PCIe endpoint
- Digital I/O
  - 16 ESD-protected 5 V-tolerant TTL lines
  - Direction individually programmable
- 8 channels 16 bit analog input
  - Simultaneous sampling
  - differential or single-ended inputs
  - Programmable input voltage (one setting for all channels):  
0-5 V, 0-10 V, 0-12.5 V,  
±2.5 V, ±5 V, ±6.25 V, ±10 V, ±12.5 V
  - Sampling rate: 1 Msps
  - Overvoltage protection
- 8 channels single-ended 16 bit analog output
  - Simultaneous update
  - Programmable output voltage:  
0-5 V, 0-10 V, 0-10.8 V,  
±5 V, ±10 V, ±10.8 V
  - Conversion time: typ.10 µs
  - Up to 2 kΩ resistive, 4000 pF capacitive load
  - Overcurrent protection
- Factory determined A/D and D/A correction data
- Operating temperature -40 °C to +85 °C

### Order Information

#### RoHS Compliant

- TQMC701-10R-A** 8 Analog Inputs (16 bit), 8 Analog Outputs (16 bit), 16 TTL I/O, air cooled  
**TQMC701-10R-H** 8 Analog Inputs (16 bit), 8 Analog Outputs (16 bit), 16 TTL I/O, conduction cooled

For the availability of non-RoHS compliant (lead solder) products please contact TEWS.

For the availability of conformal coated products please contact TEWS.

#### Software

- TDRV019-SW-25** Integrity Software Support  
**TDRV019-SW-42** VxWorks Software Support  
**TDRV019-SW-65** Windows Software Support  
**TDRV019-SW-82** Linux Software Support  
**TDRV019-SW-95** QNX Software Support

For other operating systems please contact TEWS.