

TVME202

4 Slot IndustryPack® VMEbus Carrier

Version 1.0

User Manual

Issue 1.0.1

January 2018

TVME202-10R

4 Slot IndustryPack VMEbus Carrier with front I/O

This document contains information, which is proprietary to TEWS TECHNOLOGIES GmbH. Any reproduction without written permission is forbidden.

TEWS TECHNOLOGIES GmbH has made any effort to ensure that this manual is accurate and complete. However TEWS TECHNOLOGIES GmbH reserves the right to change the product described in this document at any time without notice.

TEWS TECHNOLOGIES GmbH is not liable for any damage arising out of the application or use of the device described herein.

Style Conventions

Hexadecimal characters are specified with prefix 0x, i.e. 0x029E (that means hexadecimal value 029E).

For signals on hardware products, an ‚Active Low‘ is represented by the signal name with # following, i.e. IP_RESET#.

Access terms are described as:

W	Write Only
R	Read Only
R/W	Read/Write
R/C	Read/Clear
R/S	Read/Set

©2018 by TEWS TECHNOLOGIES GmbH

All trademarks mentioned are property of their respective owners.

Issue	Description	Date
1.0	First Issue	March 2007
1.0.1	General Revision	January 2018

Table of Contents

1	PRODUCT DESCRIPTION	6
2	TECHNICAL SPECIFICATION	7
3	CONFIGURATION	8
	3.1 VME A16 Base Address.....	9
	3.2 Interrupts	11
	3.3 VME A24/A32 Memory Enable and Size.....	12
	3.4 VME A24/A32 Base Address	13
4	IP IRQ AND CONTROL REGISTER	15
	4.1 IP IRQ Configuration Register	15
	4.2 IP Control Register.....	17
5	IP STROBE SIGNAL	19
6	INSTALLATION OF INDUSTRYPACKS	20
7	FRONT PANEL INDICATORS	21
	7.1 ACK and Power LEDs.....	21
	7.2 Fuses and Filters.....	21
8	PIN ASSIGNMENT	22
	8.1 IP J1 Connectors.....	22
	8.2 IP J2 to I/O Connector Mapping.....	23
	8.3 VMEbus Connectors	24
	8.3.1 VMEbus P1 Connector	24
	8.3.2 VMEbus P2 Connector	25

List of Figures

FIGURE 1-1 : BLOCK DIAGRAM.....	6
FIGURE 3-1 : ROTARY SWITCH S1 – S6.....	8
FIGURE 3-3 : VME A16 BASE ADDRESS	9
FIGURE 3-6 : INTERRUPT MAPPING	11
FIGURE 3-7 : VME INTERRUPT MAPPING BY S3	11
FIGURE 3-8 : VME A24/A32 MEMORY ENABLE AND SIZE.....	12
FIGURE 3-10: VME A24/A32 BASE ADDRESS.....	13
FIGURE 5-1 : IP STROBE SIGNAL	19
FIGURE 7-1 : FRONT PANEL.....	21
FIGURE 8-1 : CONNECTOR OVERVIEW	22

List of Tables

TABLE 2-1 : TECHNICAL SPECIFICATION.....	7
TABLE 3-1 : CONFIGURATION STEPS.....	8
TABLE 3-2 : VME A16 ADDRESS MAP (S3 = “0” TO “7”)	10
TABLE 3-3: VME A16 ADDRESS MAP (S3 = “8” TO “F”)	10
TABLE 3-4 : VME MEMORY SIZE BY S4.....	12
TABLE 3-5 : VME A24/A32 ADDRESS MAP	14
TABLE 4-1 : IP IRQ CONFIGURATION REGISTERS (IP A / IP B).....	15
TABLE 4-2 : IP IRQ CONFIGURATION REGISTERS (IP C / IP D)	16
TABLE 4-3 : IP CONTROL REGISTERS (IP A / IP B).....	17
TABLE 4-4 : IP CONTROL REGISTERS (IP C / IP D)	18
TABLE 7-1 : IP ACK LED	21
TABLE 7-2 : IP POWER LED	21
TABLE 8-1 : IP J1 LOGIC INTERFACE PIN ASSIGNMENT	22
TABLE 8-2 : IP J2 TO I/O CONNECTOR MAPPING.....	23
TABLE 8-3 : VMEBUS P1 CONNECTOR.....	24
TABLE 8-4 : VMEBUS P2 CONNECTOR TVME202-10R.....	25

1 Product Description

The TVME202 is a 6U VMEbus Carrier for up to 4 single-size or two double-size IndustryPack (IP) modules used to build modular, flexible and cost effective I/O solutions for applications in process control, medical systems, telecommunication and traffic control.

The TVME202 is designed in accordance to VMEbus Specification ANSI/VITA 1-1994 and the IndustryPack Logic Interface Specification ANSI/VITA 4-1995. It guarantees compatibility with the wide range of IndustryPacks in a VMEbus system.

IndustryPack I/O and ID spaces are mapped into the VME A16/D16 space.

IP Memory spaces are mapped into the VME A24 or A32 space. D08 and D16 accesses are supported. If mapped in the VME A24 space, the size of the required memory space is configurable. In VME A32 space, there is a fixed space of 8 Mbyte for each IP module.

Strobe signals of all IP modules are accessible via a 4 pin jumper block on the TVME202.

DMA, 32 bit access and 32 MHz operations are not supported.

Four 50 pin, 0.1 inch flat ribbon cable connectors provide access to all IP I/O lines. Status indicators for IP access, +5V and +/-12V are provided.

A set of 16-position rotary switches allows easy configuration of VME Short I/O and Memory addresses. Interrupt routing from the IP slots to the VME IRQ's can be done in two ways: programmable by software or selection of predefined sets by a rotary switch.

The IP power lines are fuse protected by self healing fuses and RF filtered. The operating temperature range is -40°C and +85°C.

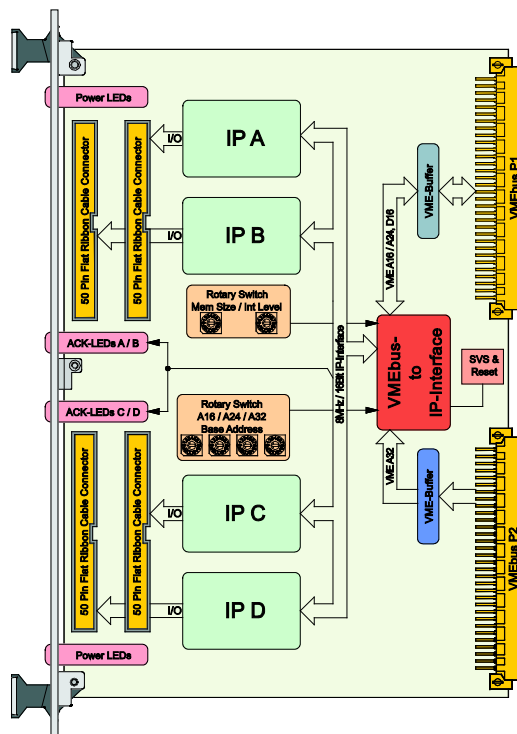

Figure 1-1 : Block Diagram

2 Technical Specification

VMEbus Slave Interface	According to VMEbus specification, ANSI / VITA 1-1994, 6U Board	
Short I/O	VME A16, D08/16, Address Modifier: 29, 2D Size: 1 Kbytes (256 Bytes / IP)	
Standard Memory	VME A24, D08/16, Address Modifier: 39, 3A, 3D, 3E Size: programmable from 32 Kbytes to 2 Mbytes per IP	
Extended Memory	VME A32, D08/16, Address Modifier: 09, 0A, 0D, 0E Size: fixed, 8 Mbytes per IP	
Interrupts	VME IRQ1-7	
IP Interface	According to IndustryPack specification ANSI / VITA 4-1995	
IP Slots	Four single size or two double size with front panel I/O	
Mapping of IP Interrupts to VMEbus	Programmable by software or selection of predefined sets by a rotary switch	
I/O access	50 pin 0.1 inch flat ribbon cable connector per IP	
DMA	Not supported	
32 MHz	Not supported	
Status LEDs	ACK LED for each IP slot +5V Power LED for each IP slot +12V and -12V Power LED	
Protection	Self healing fuses and RF-filtering on all IP power lines	
Operating Data		
Power Requirements without IP Modules	300 mA typical @+ 5 VDC 1 mA typical @+ 12 VDC 1 mA typical @ -12 VDC	
	Additional Power is required by IP modules	
Temperature Range	Operating	- 40°C to + 85C
	Storage	- 40°C to + 125°C
MTBF	366000 h MTBF values shown are based on calculation according to MIL-HDBK-217F and MIL-HDBK-217F Notice 2; Environment: G _B 20°C. The MTBF calculation is based on component FIT rates provided by the component suppliers. If FIT rates are not available, MIL-HDBK-217F and MIL-HDBK-217F Notice 2 formulas are used for FIT rate calculation.	
Weight	295 g – no IndustryPack inserted	
Size	Single Size 6U Euro Card	
Humidity	5 – 95 % non-condensing	

Table 2-1 : Technical Specification

3 Configuration

Setting 6 rotary switches allows all required configuration of the TVME202. Position of the switches is shown below:

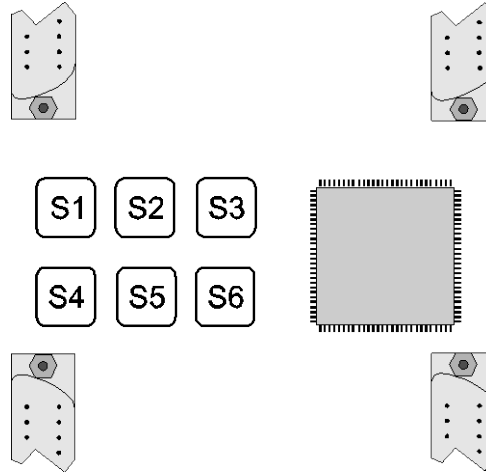

Figure 3-1 : Rotary Switch S1 – S6

Step	Rotary Switch	Function	Default Value
1	S1 / S2	VME A16 Base Address	0x6000
2	S3	Interrupt Mapping	VIPC6xx compatible
3	S4	VME A24/A32 Memory Enable and Memory Size	Disabled
4	S5 / S6	VME A24/A32 Memory Base Address	A24: 0xD00000 A32: 0xD0000000

Table 3-1 : Configuration Steps

3.1 VME A16 Base Address

The VME A16 Base Address of the TVME202 is set by rotary switch S1 and S2.

Rotary switch S1 sets A[15:12] of the VME A16 Base Address.

Rotary switch S2 sets A[11:10] of the VME A16 Base Address.

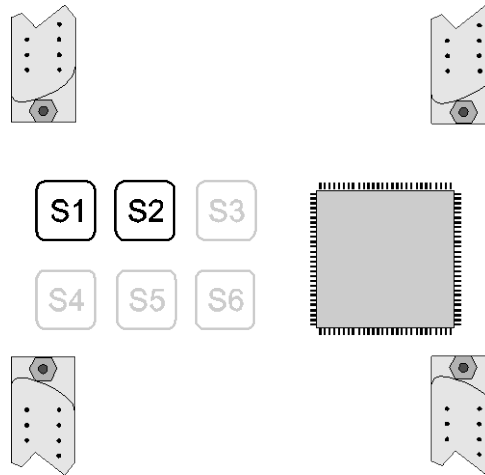
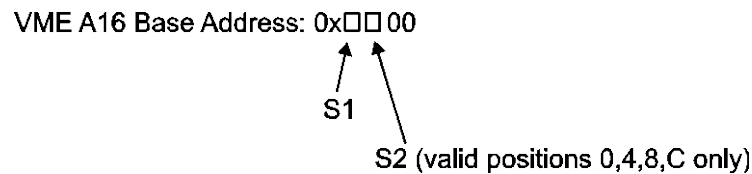

Figure 3-2 : VME A16 Base Address



The default value for the VME A16 Base Address is 0x6000 (S1=6, S2=0).

The TVME202 requires an address space of 1 Kbytes within the VME A16 address space. Each of the four IP slots occupies 256 bytes within this 1 Kbytes VME A16 address space.

The address space for each IP is divided into the following areas: IP I/O space, IP ID space and the IP IRQ and Control Register.

The IP I/O space has a size of 128 bytes. The size of the IP ID space and the IP IRQ and Control Register depends on the position of switch S3:

With S3 = "0" to "7", the IP IRQ and Control Registers of the TVME202 are accessible, and the size of the IP ID space is 64 bytes. The remaining 64 bytes are occupied by the IP IRQ and Control Registers. If switch S3 = "8" to "F", the IP IRQ and Control Registers of the TVME202 are not accessible, and the corresponding address range is added to the IP ID space, resulting in a size of 128 bytes for the IP ID space with S3 = "8" to "F". This configuration is necessary for IP modules that require access to the ID Space above the ID PROM.

See figures below for more details.

VME A16 Base Address	Description	Default
+ 0x0000	I/O Space IP A	0x6000
+ 0x0080	ID Space IP A	0x6080
+ 0x00C0	IRQ and Control Register IP A	0x60C0
+ 0x0100	I/O Space IP B	0x6100
+ 0x0180	ID Space IP B	0x6180
+ 0x01C0	IRQ and Control Register IP B	0x61C0
+ 0x0200	I/O Space IP C	0x6200
+ 0x0280	ID Space IP C	0x6280
+ 0x02C0	IRQ and Control Register IP C	0x62C0
+ 0x0300	I/O Space IP D	0x6300
+ 0x0380	ID Space IP D	0x6380
+ 0x03C0	IRQ and Control Register IP D	0x63C0

Table 3-2 : VME A16 Address Map (S3 = “0” to “7”)

VME A16 Base Address	Description	Default
+ 0x0000	I/O Space IP A	0x6000
+ 0x0080	ID Space IP A	0x6080
+ 0x0100	I/O Space IP B	0x6100
+ 0x0180	ID Space IP B	0x6180
+ 0x0200	I/O Space IP C	0x6200
+ 0x0280	ID Space IP C	0x6280
+ 0x0300	I/O Space IP D	0x6300
+ 0x0380	ID Space IP D	0x6380

Table 3-3: VME A16 Address Map (S3 = “8” to “F”)

3.2 Interrupts

Each IndustryPack can generate interrupts on two interrupt request lines (INT0 and INT1). The VMEbus offers seven interrupt request level. IRQ7 has the highest priority, IRQ1 has the lowest priority.

IP interrupt requests can be mapped to any of the 7 VME interrupt request levels. Interrupt routing from the IP slots to the VME IRQs can be done by selection of predefined sets with a rotary switch or programmable by software if S3 is in the range of "0" to "7".

For more information about fully programmable interrupt mapping please refer to chapter "IP IRQ and Control Register".

Rotary switch S3 can be used to select predefined sets of mapping of the eight IP interrupt request (two requests per IP slot) to the seven VME interrupt request level. The mapping selected with S3 = "0" to "7" is mirrored at S3 = "8" to "F". The difference is that access to the IP IRQ and Control Registers of the TVME202 is only possible in switch position S3 = "0" to "7". See chapter "IP IRQ and Control Register" and chapter "VME A16 Base Address" for more details.

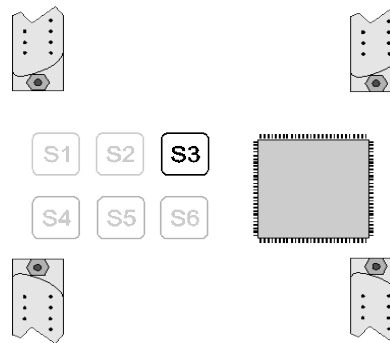

Figure 3-3 : Interrupt Mapping

S3 =	0	1	2	3	4	5...7	8*	9*	A*	B*	C*	D*...F*
IP A, Int0	-	1	4	6	1	reserved	-	1	4	6	1	reserved
IP A, Int1	-	2	5	4	1	reserved	-	2	5	4	1	reserved
IP B, Int0	-	3	2	3	2	reserved	-	3	2	3	2	reserved
IP B, Int1	-	4	1	1	2	reserved	-	4	1	1	2	reserved
IP C, Int0	-	5	4	6	3	reserved	-	5	4	6	3	reserved
IP C, Int1	-	6	5	4	3	reserved	-	6	5	4	3	reserved
IP D, Int0	-	7	2	3	4	reserved	-	7	2	3	4	reserved
IP D, Int1	-	-	1	1	4	reserved	-	-	1	1	4	reserved

"-" = No VME IRQ level mapped to IP INTx

* no access to the IP IRQ and Control registers of the TVME202 , see Chapter 4 and Chapter 3.1 for more details.

Figure 3-4 : VME Interrupt Mapping by S3

S3 = "1", "9" corresponds to the VME Interrupt Mapping of the VIPC6xx.

S3 = "2", "A" corresponds to the VME Interrupt Mapping of the VIPC610-01 (equal to two VIPC310).

S3 = "3", "B" corresponds to the VME Interrupt Mapping of another version of the VIPC310.

The default value for S3 is "1".

3.3 VME A24/A32 Memory Enable and Size

If VME memory space is not required, switch S4 to “0” (VME A24/A32 memory disabled).

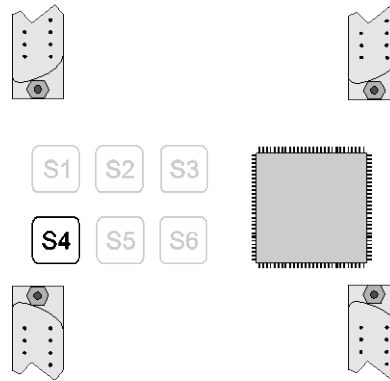

Figure 3-5 : VME A24/A32 Memory Enable and Size

IndustryPack Memory is mapped into the VME A24 or VME A32 memory space.

In VME A24 memory space, the memory size can be configured from 32 Kbytes to 2 Mbyte memory per IP slot.

In VME A32 memory space, the memory size is fixed 8 Mbyte per IP slot.

Rotary switch S4 is used to enable/disable VME A24/A32 memory and to select the required VME memory size. Default setting of S4 is “0”, which signifies VME A24/A32 memory is disabled.

Positions “1” to “7” of S4 represent several memory spaces in VME A24, and with S4 = “F”, each IP has an 8 Mbyte memory space in VME A32 address space.

The Memory Spaces for all IPs have the same size. If i.e. one IP requires 128 Kbytes of memory, one IP requires 64 Kbytes of memory and 2 IP require no memory, then S4 must be set to “3”, which selects a VME A24 memory size of 512 Kbytes, 128 Kbytes memory for each IP.

Value of S4:	VME Memory Size:		
0x0	VME A24/A32 memory disabled		
0x1	A24	128 Kbytes	32 Kbytes / IP
0x2	A24	256 Kbytes	64 Kbytes / IP
0x3	A24	512 Kbytes	128 Kbytes / IP
0x4	A24	1 Mbytes	256 Kbytes / IP
0x5	A24	2 Mbyte	512 Kbytes / IP
0x6	A24	4 Mbyte	1 Mbyte / IP
0x7	A24	8 Mbyte	2 Mbyte / IP
0x8 – 0xE	reserved		
0xF	A32	32 Mbyte	8 Mbyte / IP Slot

Table 3-4 : VME Memory Size by S4

3.4 VME A24/A32 Base Address

The memory space of IndustryPacks is mapped in the VME A24 or VME A32 space.

The memory base address for VME A24 or VME A32 is both set with the switches S5 and S6.

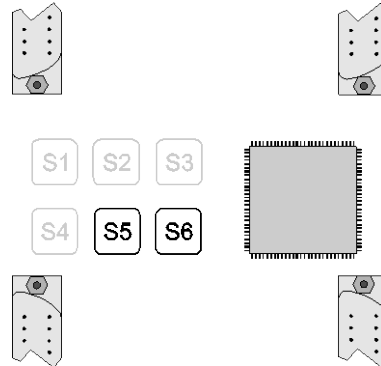
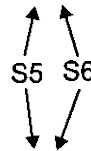

Figure 3-6: VME A24/A32 Base Address

If memory space is located in VME A24, S5 represents A[23:20], and S6 represents A[19:16].

In VME A32, S5 represents [A31:28] and S6 represents A[27:24].

VME A24 Base Address: 0x□□0000



VME A32 Base Address: 0x□□□0000000

The memory base address of the TVME202 must be set on a boundary, equal to the memory size, as selected by S4! See figure below for details.

The default value for VME A24 base address is 0xD00000 (S5=D, S6=0).

The default value for VME A32 base address is 0xD0000000 (S5=D, S6=0).

TVME202 VME A24/A32 Size		IP Memory Size	IP Slot	IP Memory Location: Mem. Base Address +	VMEbus Address Boundary
A24	128 Kbytes	32 Kbytes	A	0x000000	multiple of 0x020000
		32 Kbytes	B	0x008000	
		32 Kbytes	C	0x010000	
		32 Kbytes	D	0x018000	
A24	256 Kbytes	64 Kbytes	A	0x000000	multiple of 0x040000
		64 Kbytes	B	0x010000	
		64 Kbytes	C	0x020000	
		64 Kbytes	D	0x030000	
A24	512 Kbytes	128 Kbytes	A	0x000000	multiple of 0x080000
		128 Kbytes	B	0x020000	
		128 Kbytes	C	0x040000	
		128 Kbytes	D	0x060000	
A24	1 Mbytes	256 Kbytes	A	0x000000	multiple of 0x100000
		256 Kbytes	B	0x040000	
		256 Kbytes	C	0x080000	
		256 Kbytes	D	0x0C0000	
A24	2 Mbytes	512 Kbytes	A	0x000000	multiple of 0x200000
		512 Kbytes	B	0x080000	
		512 Kbytes	C	0x100000	
		512 Kbytes	D	0x180000	
A24	4 Mbytes	1 Mbytes	A	0x000000	multiple of 0x400000
		1 Mbytes	B	0x100000	
		1 Mbytes	C	0x200000	
		1 Mbytes	D	0x300000	
A24	8 Mbytes	2 Mbytes	A	0x000000	multiple of 0x800000
		2 Mbytes	B	0x200000	
		2 Mbytes	C	0x400000	
		2 Mbytes	D	0x600000	
A32	32 Mbytes	8 Mbytes	A	0x00000000	multiple of 0x02000000
		8 Mbytes	B	0x00800000	
		8 Mbytes	C	0x01000000	
		8 Mbytes	D	0x01800000	

Table 3-5 : VME A24/A32 Address Map

4 IP IRQ and Control Register

If switch S3 is in the range of “0” to “7”, the TVME202 provides a set of two registers for each IP: The IP IRQ Configuration Register and the IP Control Register.

Setting switch S3 to a value of “8” to “F” disables the IP IRQ Register and the IP Control Register. The address range of the IP IRQ and Control Register from “VME A16 Base Address” + “IP Offset” + 0xC0 to 0xFF is then mapped to the ID Space of the corresponding IP module, enlarging the ID Space of each IP module from 64 bytes to 128 bytes.

4.1 IP IRQ Configuration Register

Switch S3 must be in the range of “0” to “7” to access the IP IRQ Configuration Register. The register is divided in 2 equal parts, one for each interrupt. The bits[0, 4] are the LSBs, and the bits[2, 6] are the MSBs of the programmed IRQ level.

IP A IRQ Configuration Register		VME A16 Base Address + 0x00C1		
Bit	Symbol	Description	Access	Reset Value
7				
6	IP A, INT1	VME IRQ Level	R/W	Depends on S3 jumper setting
5		000 = interrupt is disabled	R/W	
4		[6:4] 001 to 111 = VMEbus IRQ levels IRQ1 to IRQ7	R/W	
3			R/W	
2	IP A, INT0	VME IRQ Level	R/W	Depends on S3 jumper setting
1		000 = interrupt is disabled	R/W	
0		[2:0] 001 to 111 = VMEbus IRQ levels IRQ1 to IRQ7	R/W	

IP B IRQ Configuration Register		VME A16 Base Address + 0x01C1		
Bit	Symbol	Description	Access	Reset Value
7				
6	IP B, INT1	VME IRQ Level	R/W	Depends on S3 jumper setting
5		000 = interrupt is disabled	R/W	
4		[6:4] 001 to 111 = VMEbus IRQ levels IRQ1 to IRQ7	R/W	
3			R/W	
2	IP B, INT0	VME IRQ Level	R/W	Depends on S3 jumper setting
1		000 = interrupt is disabled	R/W	
0		[2:0] 001 to 111 = VMEbus IRQ levels IRQ1 to IRQ7	R/W	

Table 4-1 : IP IRQ Configuration Registers (IP A / IP B)

IP C IRQ Configuration Register		VME A16 Base Address + 0x02C1		
Bit	Symbol	Description	Access	Reset Value
7				
6	IP C, INT1	VME IRQ Level	R/W	Depends on S3 jumper setting
5		000 = interrupt is disabled	R/W	
4		[6:4] 001 to 111 = VMEbus IRQ levels IRQ1 to IRQ7	R/W	
3			R/W	
2	IP C, INT0	VME IRQ Level	R/W	Depends on S3 jumper setting
1		000 = interrupt is disabled	R/W	
0		[2:0] 001 to 111 = VMEbus IRQ levels IRQ1 to IRQ7	R/W	

IP D IRQ Configuration Register		VME A16 Base Address + 0x03C1		
Bit	Symbol	Description	Access	Reset Value
7				
6	IP D, INT1	VME IRQ Level	R/W	Depends on S3 jumper setting
5		000 = interrupt is disabled	R/W	
4		[6:4] 001 to 111 = VMEbus IRQ levels IRQ1 to IRQ7	R/W	
3			R/W	
2	IP D, INT0	VME IRQ Level	R/W	Depends on S3 jumper setting
1		000 = interrupt is disabled	R/W	
0		[2:0] 001 to 111 = VMEbus IRQ levels IRQ1 to IRQ7	R/W	

Table 4-2 : IP IRQ Configuration Registers (IP C / IP D)

4.2 IP Control Register

Four IP Control Registers are located in the VMEbus A16 space. Switch S3 must be in the range of “0” to “7” to access the IP Control Register.

IP A Control Register		VME A16 Base Address + 0x00C3		
Bit	Symbol	Description	Access	Reset Value
7	IP A, Reset	1 = reset is initiated Remains '1', until the IP reset has been completed and is then set to '0' by the on board logic. It can be read to verify the status of the reset.	R/W	0
6	reserved	Carry random information	R	undefined
5	reserved		R	undefined
4	reserved		R	undefined
3	reserved		R	undefined
2	IP A, Error	1 = error signal is active	R	0
1	IP A, INT1	Interrupt status	R	0
0	IP A, INT0	1 = indicates a pending interrupt request	R	0

IP B Control Register		VME A16 Base Address + 0x01C3		
Bit	Symbol	Description	Access	Reset Value
7	IP B, Reset	1 = reset is initiated Remains '1', until the IP reset has been completed and is then set to '0' by the on board logic. It can be read to verify the status of the reset.	R/W	0
6	reserved	Carry random information	R	undefined
5	reserved		R	undefined
4	reserved		R	undefined
3	reserved		R	undefined
2	IP B, Error	1 = error signal is active	R	0
1	IP B, INT1	Interrupt status	R	0
0	IP B, INT0	1 = indicates a pending interrupt request	R	0

Table 4-3 : IP Control Registers (IP A / IP B)

IP C Control Register		VME A16 Base Address + 0x02C3		
Bit	Symbol	Description	Access	Reset Value
7	IP C, Reset	1 = reset is initiated Remains '1', until the IP reset has been completed and is then set to '0' by the on board logic. It can be read to verify the status of the reset.	R/W	0
6	reserved	Carry random information	R	undefined
5	reserved		R	undefined
4	reserved		R	undefined
3	reserved		R	undefined
2	IP C, Error	1 = error signal is active	R	0
1	IP C, INT1	Interrupt status	R	0
0	IP C, INT0	1 = indicates a pending interrupt request	R	0

IP D Control Register		VME A16 Base Address + 0x03C3		
Bit	Symbol	Description	Access	Reset Value
7	IP D, Reset	1 = reset is initiated Remains '1', until the IP reset has been completed and is then set to '0' by the on board logic. It can be read to verify the status of the reset.	R/W	0
6	reserved	Carry random information	R	undefined
5	reserved		R	undefined
4	reserved		R	undefined
3	reserved		R	undefined
2	IP D, Error	1 = error signal is active	R	0
1	IP D, INT1	Interrupt status	R	0
0	IP D, INT0	1 = indicates a pending interrupt request	R	0

Table 4-4 : IP Control Registers (IP C / IP D)

5 IP Strobe Signal

The IP strobe signal is an uncommitted line of the IP logic interface, which may be used as an optional input to or output from an IP module. It is reserved for a digital strobe or clock signal related to the functionality of the IP.

Strobe signals of each of the four IP slots are accessible on the TVME202 via a 4 pin jumper field.

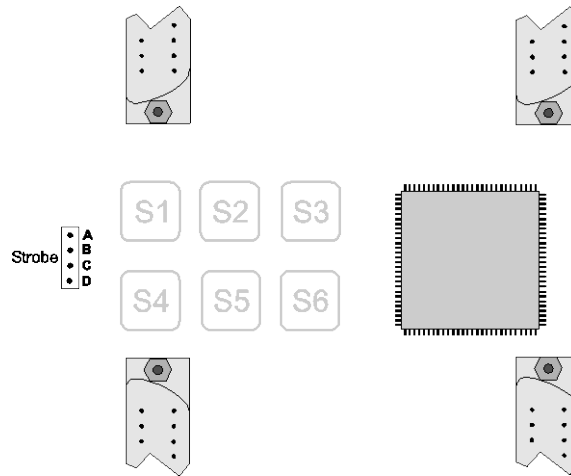

Figure 5-1 : IP Strobe Signal

6 Installation of IndustryPacks

Before installing an IndustryPack, be sure that the power supply for the TVME202 is turned off.

The component is an Electrostatic Sensitive Device (ESD). Use an anti-static mat connected to a wristband when handling or installing the components.

Installing IndustryPacks on the TVME202 is done by simply snapping them into one of the four IP slots. The connectors are keyed, so the IndustryPack can only be installed correctly.

After an IP has been installed it can be secured on the carrier board. This is normally necessary only in high vibration or shock environments.

Screws and spacers are required to fix a single IP on the TVME202. They can be ordered from TEWS TECHNOLOGIES GmbH (Part number: TIPxxx-HK).

All IPs mate with 50-pin flat cable receptacle connectors for their I/O. On the TVME202 all connectors are accessible behind the front panel. The board labeling indicates which connector is associated with the according IP slot. Pin 1 for each cable is identified by the mark on the connector or a square solder pad.

7 Front Panel Indicators

7.1 ACK and Power LEDs

For a quick visual inspection the TVME202 offers a total of 10 LEDs in the front panel.

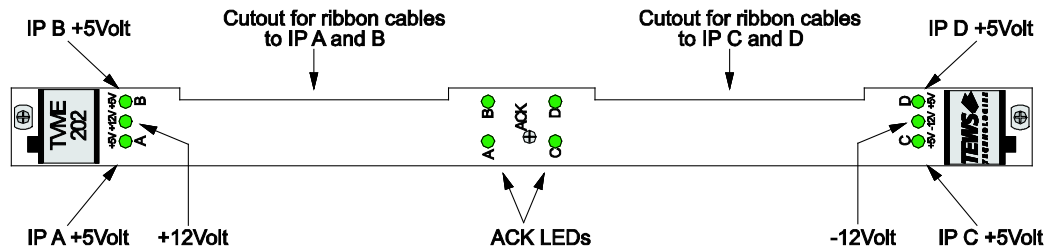

Figure 7-1 : Front Panel

Each IndustryPack has its own “ACK” LED, which is lit for about 200ms whenever an access to the corresponding IP happens.

Function	Label	Color	Description
IP A ACK	A	green	Indicates access to IP A
IP B ACK	B	green	Indicates access to IP B
IP C ACK	C	green	Indicates access to IP C
IP D ACK	D	green	Indicates access to IP D

Table 7-1 : IP ACK LED

Additionally there are 6 green Power LEDs in the front panel of the TVME202:

Function	Label	Color	Description
IP A +5V	+5V A	green	LED = “on”: IP power supply ok
IP B +5V	+5V B	green	
IP C +5V	+5V C	green	
IP D +5V	+5V D	green	
+12V common to all IP	+12V	green	LED = “on”: +12V power ok
-12V common to all IP	-12V	green	LED = “on”: -12V power ok

Table 7-2 : IP Power LED

7.2 Fuses and Filters

All IP slots are fuse protected. The fuses used on the TVME202 are self-healing fuses. For improved performance the TVME202 provides RF filtering and decoupling capacitors on all IP power lines.

8 Pin Assignment

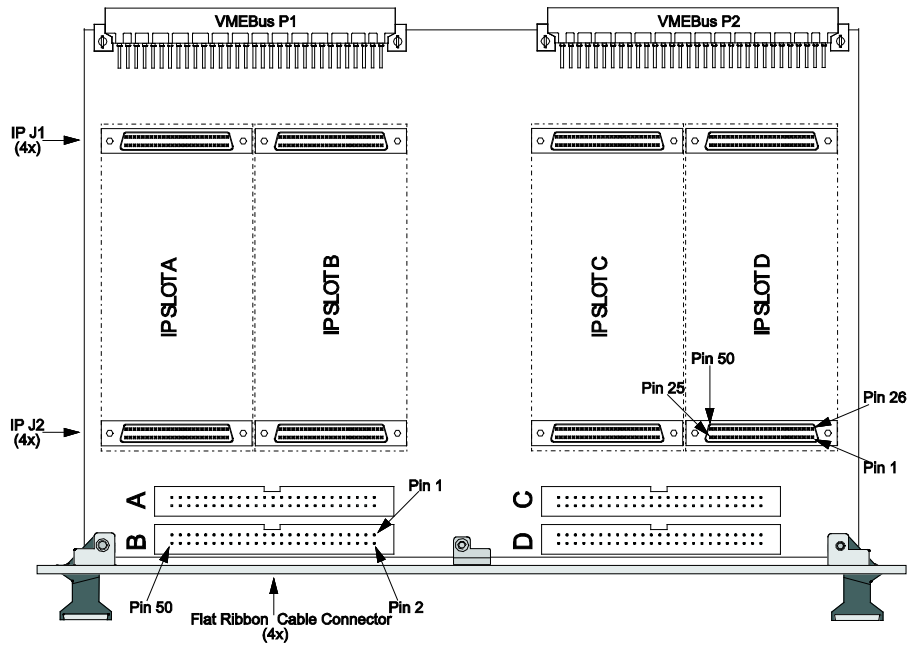

Figure 8-1 : Connector Overview

8.1 IP J1 Connectors

The table below shows the complete IP J1 logic interface pin assignments. Some of these signals are not used on the TVME202.

Pin #	Signal	Pin #	Signal	Pin #	Signal	Pin #	Signal
1	GND	2	CLK	26	GND	27	+5V
3	Reset#	4	D0	28	R/W#	29	IDSel#
5	D1	6	D2	30	DMAReq0#	31	MemSel#
7	D3	8	D4	32	DMAReq1#	33	IntSel#
9	D5	10	D6	34	DMAck#	35	IOSel#
11	D7	12	D8	36	Reserved	37	A1
13	D9	14	D10	38	DMAEnd#	39	A2
15	D11	16	D12	40	Error#	41	A3
17	D13	18	D14	42	IntReq0#	43	A4
19	D15	20	BS0#	44	IntReq1#	45	A5
21	BS1#	22	-12V	46	Strobe#	47	A6
23	+12V	24	+5V	48	ACK#	49	Reserved
25	GND			50	GND		

Table 8-1 : IP J1 Logic Interface Pin Assignment

8.2 IP J2 to I/O Connector Mapping

The IP J2 I/O connector routes the IP I/O lines directly to the appropriate pins of the 50 pin IP I/O ribbon cable connector. The pin assignment of the IP J2 I/O connector is IP specific.

Flat Ribbon Cable Conn. Pin #	IP J2 Pin #	Flat Ribbon Cable Conn. Pin #	IP J2 Pin #
1	1	26	26
2	2	27	27
3	3	28	28
4	4	29	29
5	5	30	30
6	6	31	31
7	7	32	32
8	8	33	33
9	9	34	34
10	10	35	35
11	11	36	36
12	12	37	37
13	13	38	38
14	14	39	39
15	15	40	40
16	16	41	41
17	17	42	42
18	18	43	43
19	19	44	44
20	20	45	45
21	21	46	46
22	22	47	47
23	23	48	48
24	24	49	49
25	25	50	50

Table 8-2 : IP J2 to I/O Connector Mapping

8.3 VMEbus Connectors

8.3.1 VMEbus P1 Connector

Pin	Row A	Row B	Row C
1	VME_D0	VME_BBSY#	VME_D8
2	VME_D1	VME_BCLR#	VME_D9
3	VME_D2	VME_ACFAIL#	VME_D10
4	VME_D3	VME_BGIN0#	VME_D11
5	VME_D4	VME_BGOUT0#	VME_D12
6	VME_D5	VME_BGIN1#	VME_D13
7	VME_D6	VME_BGOUT1#	VME_D14
8	VME_D7	VME_BGIN2#	VME_D15
9	GND	VME_BGOUT2#	GND
10	VME_SYSCLK	VME_BGIN3#	VME_SYSFAIL#
11	GND	VME_BGOUT3#	VME_BERR#
12	VME_DS1#	VME_BR0#	VME_SYSRST#
13	VME_DS0#	VME_BR1#	VME_LWORD#
14	VME_WRITE#	VME_BR2#	VME_AM5
15	GND	VME_BR3#	VME_A23
16	VME_DTACK#	VME_AM0	VME_A22
17	GND	VME_AM1	VME_A21
18	VME_AS#	VME_AM2	VME_A20
19	GND	VME_AM3	VME_A19
20	VME_IACK#	GND	VME_A18
21	VME_IACKIN#	NC	VME_A17
22	VME_IACKOUT#	NC	VME_A16
23	VME_AM4	GND	VME_A15
24	VME_A7	VME_IRQ7#	VME_A14
25	VME_A6	VME_IRQ6#	VME_A13
26	VME_A5	VME_IRQ5#	VME_A12
27	VME_A4	VME_IRQ4#	VME_A11
28	VME_A3	VME_IRQ3#	VME_A10
29	VME_A2	VME_IRQ2#	VME_A9
30	VME_A1	VME_IRQ1#	VME_A8
31	-12V	NC	+12V
32	+5V	+5V	+5V

Table 8-3 : VMEbus P1 Connector

8.3.2 VMEbus P2 Connector

Pin	Row A	Row B	Row C
1	NC	+5V	NC
2	NC	GND	NC
3	NC	NC	NC
4	NC	VME_A24	NC
5	NC	VME_A25	NC
6	NC	VME_A26	NC
7	NC	VME_A27	NC
8	NC	VME_A28	NC
9	NC	VME_A29	NC
10	NC	VME_A30	NC
11	NC	VME_A31	NC
12	NC	GND	NC
13	NC	+5V	NC
14	NC	NC	NC
15	NC	NC	NC
16	NC	NC	NC
17	NC	NC	NC
18	NC	NC	NC
19	NC	NC	NC
20	NC	NC	NC
21	NC	NC	NC
22	NC	GND	NC
23	NC	NC	NC
24	NC	NC	NC
25	NC	NC	NC
26	NC	NC	NC
27	NC	NC	NC
28	NC	NC	NC
29	NC	NC	NC
30	NC	NC	NC
31	NC	GND	NC
32	NC	+5V	NC

Table 8-4 : VMEbus P2 Connector TVME202-10R