

TXMC590 16 Channel Thermo-/Strain-Measurement XMC

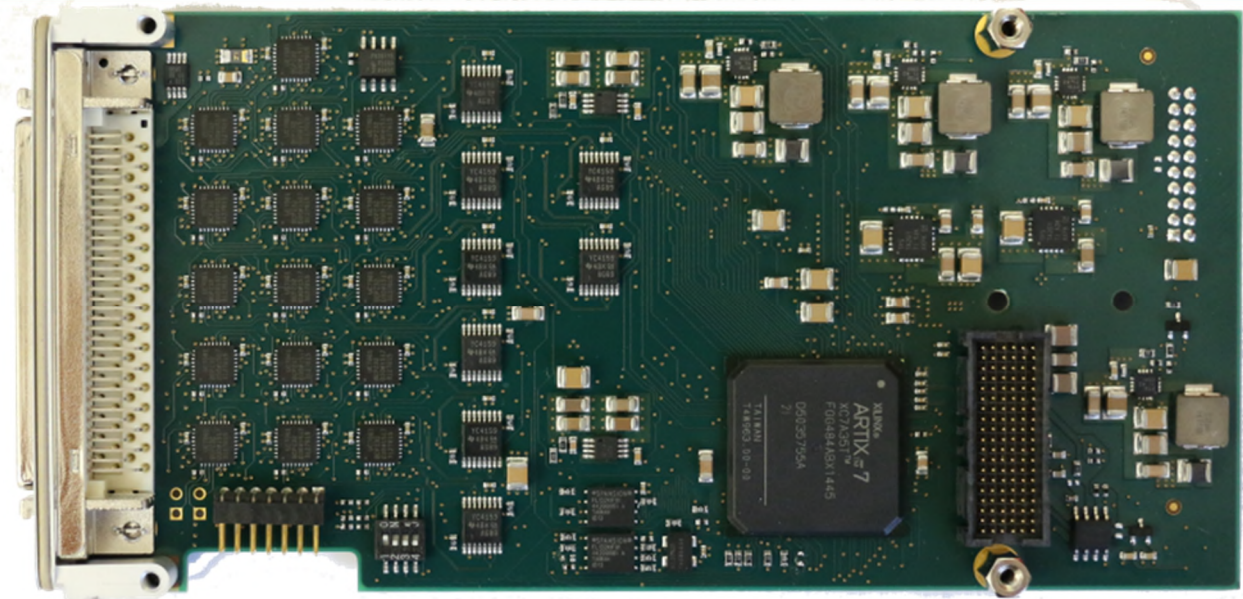

TXMC590-10R

Application Information

The Thermo-/Strain-Measurement XMC module TXMC590 is able to measure thermocouples, resistive sensors like RTD and thermistors, and strain gauges.

It provides 16 non-isolated independent measurement channels. Each channel consists of a differential analog input and a differential sensor excitation output. The setup of the analog in-/outputs, the signal conditioning and the translation into data values is handled by a microcontroller with an integrated ADC and current source.

The TXMC590 is suitable for measuring any kind of ungrounded thermocouples. The cold junction compensation is done onboard, freeing the user application from this task. There are three possibilities to measure the cold junction temperature:

- 1) A second channel configured as resistive temperature sensor
- 2) An onboard I2C temperature sensor
- 3) An external I2C temperature sensor (not included)

For measuring RTDs ratio metric, there is a high precision reference resistor onboard. The excitation current is set up automatically according to the RTD channel settings.

All Strain Gauge types are supported (e.g. quarter, half and full bridge configurations). However, there is no bridge completion circuit onboard the TXMC590. Therefore, if quarter or half bridges are used, these have to be

completed outside of the module. The excitation current is set up automatically according to the strain gauge channel settings. As well, every channel can be calibrated and the measured value is cleared of offset errors.

Each channel can separately be configured for any sensor type. The measured value is translated into a data value according to the sensor type, i.e. into temperature or microstrain. The translation may be set up to provide the data in a format that allows direct usage without further calculations. Measurements can be set up to operate periodically with different time bases or can be triggered via register access.

The TXMC590 features predefined parameter sets for the most common sensor types. Additionally, up to 16 user-defined parameter sets can be persistently stored on board. These user-defined parameter sets allow supporting even user defined sensors. A software tool to build these user-defined parameter sets is part of TXMC590-SW-xx.

For special customer requirements, the microcontroller is also programmable via PCI Express which allows developing and programming special firmware into the controller.

Software Support (TXMC590-SW-xx) is available for different operating systems.

Technical Information

- Form Factor: Standard single-width XMC module conforming to ANSI/VITA 42.0-2008 (R2015)
 - Board size: 149 mm x 74 mm
 - x1/x4 PCI Express (Base Specification 1.1) compliant interface conforming to ANSI/VITA 42.3
 - IPMI resource: FRU hardware definition information stored in onboard EEPROM
 - Interrupts configurable for channel configuration cycles and for channel conversion cycles
- 16 analog thermo-/strain measurement channels based on ADuC7061 Microcontroller, capable of measuring:
 - Ungrounded Thermocouples
 - Resistive Sensors (e.g. RTD)
 - Strain Gauges
- 16x Sensor excitation onboard
- Onboard Cold Junction Compensation for Thermocouples with several options
- 16 pre-defined parameter sets for standard sensors
- 16 user-definable parameter sets for specific sensors storable in flash memory
- Operating temperature: -40°C to +85°C
- MTBF (MIL-HDBK217F/FN2 G_B 20°C): 464000h

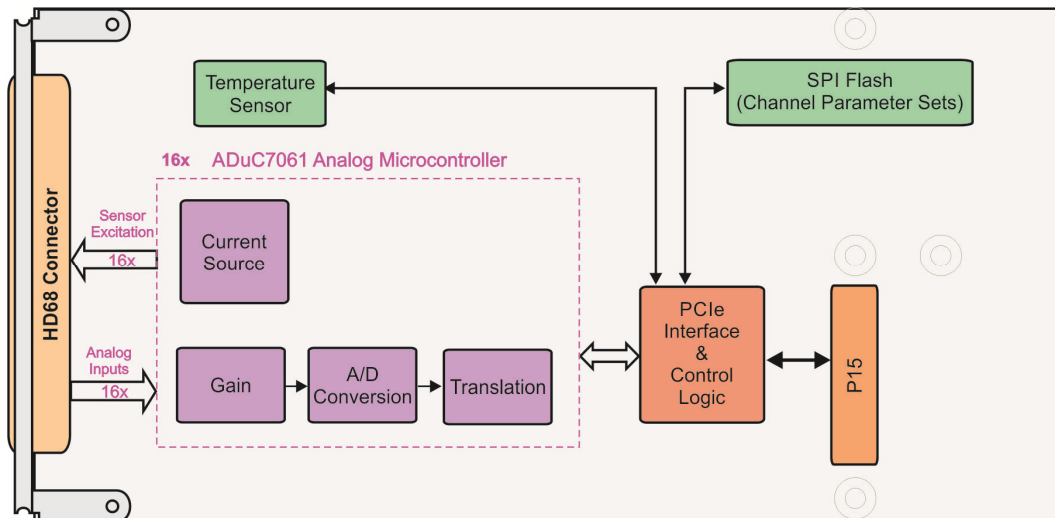

Order Information

RoHS Compliant

TXMC590-10R 16 Channel Thermo-/Strain-Measurement

For the availability of non-RoHS compliant (lead solder) products please contact TEWS.

Documentation

TXMC590-DOC User Manual

Software

TXMC590-SW-25 Integrity Software Support
TXMC590-SW-42 VxWorks Software Support (Legacy and VxBus-Enabled Software Support)
TXMC590-SW-65 Windows Software Support
TXMC590-SW-82 Linux Software Support
TXMC590-SW-95 QNX Software Support

For other operating systems please contact TEWS.