

TXMC888 Two Channel SFP+ 10Gb Ethernet Interface

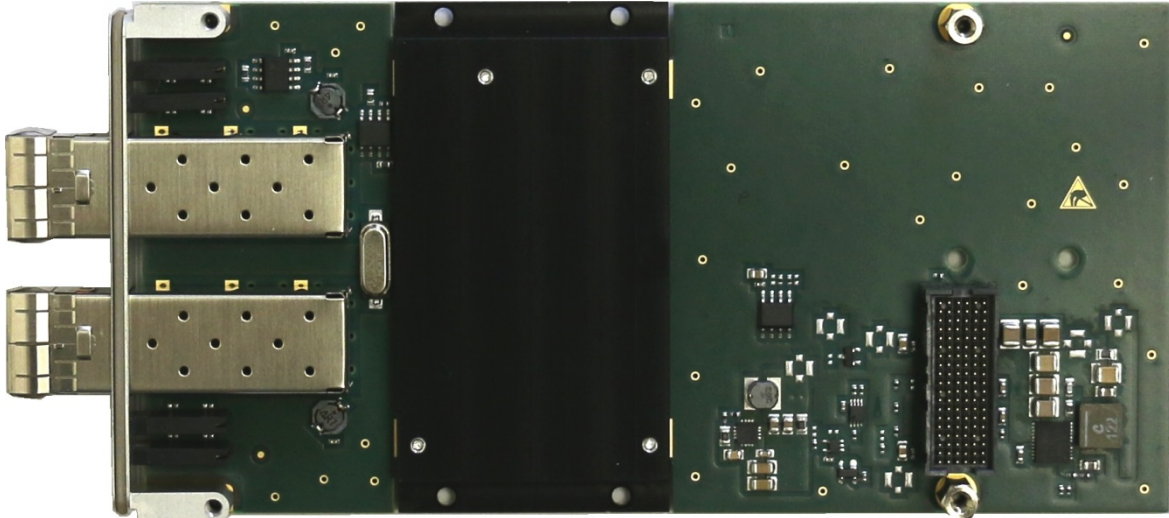

Application Information

The TXMC888 is a Switched Mezzanine Card (XMC) compatible module providing a two channel 10 Gigabit Ethernet Enhanced Small Form Factor Pluggable (SFP+) interface.

The XMC-Connector P15 provides access to the Intel™ 82599ES dual port 10GbE controller via an x8 PCIe link.

The TXMC888's SFP+ Cages accept various SFP and SFP+ transceiver modules. These two SFP+ hosts are connected to the Ethernet Controller's SFI Interfaces.

The following transceiver modules have been successfully tested with the TXMC888:

- Intel XDACBL1M (SFP+ Direct Attach Twinaxial Cable)
- Finisar FCBG110SD1C01 (SFP+ SFPwire Active Optical Cable)
- Intel E10GSFPSR (SFP+ 10GBASE-SR or 1000BASE-SX)
- Finisar FTLX8571D3BCV (SFP+ 10GBASE-SR or 1000BASE-SX)
- Intel E10GSFPLR (SFP+ 10GBASE-LR or 1000BASE-LX)
- Finisar FTLX1471D3BCV (SFP+ 10GBASE-LR or 1000BASE-LX)
- Finisar FCLF8522P2BTL (SFP 1000BASE-T)

All compatible transceivers modules and replacements of the tested modules will also work properly with the TXMC888.

The controller is equipped with a 1 Mbit serial flash memory for Boot ROM and a 128 Kbit EEPROM storing configuration data. LEDs in the front panel indicate the different network activities.

For preconfigured variants of the hardware module containing transceiver modules, please contact TEWS.

The TXMC888-10R provides two 10GbE Interfaces via front panel SFP+ connectors.

Software support:

- Software support for Intel™ 82599ES at www.intel.com
- For operating systems not supported by Intel™, please contact TEWS.

Technical Information

- Form Factor: Standard single-width XMC module conforming to ANSI/VITA 42.0
 - Board size: 149 mm x 74 mm
- x8 PCI Express (Base Specification 2.0) compliant interface conforming to ANSI/VITA 42.3
- IPMI resource: FRU hardware definition information stored in on-board EEPROM
- Dual Port Intel™ 82599ES 10 Gigabit Ethernet controller providing SFI Interfaces
- Two SFP+ Cages
- 10GBase-CU (SFP+ Direct Attach, twinax)
- SFPwire SFP+ Active Optical Cable
- 10GBase-SR/SW / 1000Base-SX
- 10GBase-LR/LW / 1000Base-LX
- 1000Base-T
- 1 Mbit serial flash memory for Boot ROM
- 128 Kbit EEPROM storing configuration data
- Operating temperature 0°C to +70°C
- MTBF (MIL-HDBK217F/FN2 G_B 20°C) 555000 h

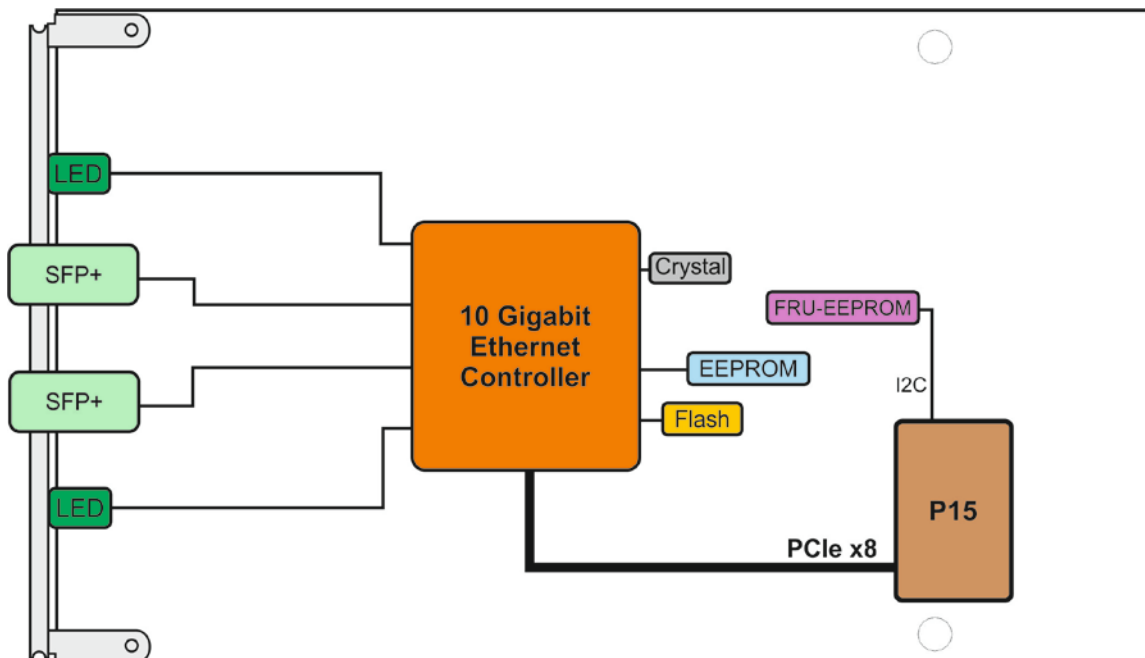

Order Information

RoHS Compliant

TXMC888-10R Two channel 10 Gigabit Ethernet interface SFP+ front panel I/O

For the availability of non-RoHS compliant (lead solder) products please contact TEWS.

Documentation

TXMC888-DOC User Manual